

**IMPORTANT:  
READ OPERATING  
INSTRUCTIONS  
CAREFULLY**

- **QUICK SET-UP, 540** .....2
- **QUICK SET-UP, 1040** ...3
- **QUICK SET-UP, 2040** ...4
- **OPERATION** .....6
- **ROBOT POSITIONS** .....12
- **MISC. ADJUSTMENTS** ...13
- **IMPORTANT NOTICES** ...15
- **TAKE-DOWN, 2040** ...16
- **ACCESSORIES** .....18
- **MAINTENANCE** .....20
- **TROUBLESHOOTING** ....21
- **EXPLODED VIEWS** .....24
- **PARTS LIST** .....26
- **WARRANTY & REPAIR**..28



NEWGY INDUSTRIES, INC.  
805 TEAL DRIVE  
GALLATIN, TN 37066 USA  
PHONE 615-452-6470  
FAX 615-230-9785  
E-MAIL newgy@newgy.com  
WEB www.newgy.com

# NEWGY **ROBO-PONG** 2040®



**ROBO-PONG**  
540

**ROBO-PONG**  
1040

## **NEWGY TABLE TENNIS ROBOT OWNER'S MANUAL**

For Models 2040, 1040, & 540

Manufactured under one or more of the following U.S. patents: 4,844,458; 4,854,588; 4,917,380; 5,009,421; 5,335,905; 5,383,658; 5,485,995; and 6,406,386. Also covered by multiple foreign patents/patents pending. Robo-Pong, Pong-Master, Robo-Balls, and Newgy are trademarks of Newgy Industries, Inc., 805 Teal Drive, Gallatin, TN 37066 USA.

©January, 2007

# NEWGY TABLE TENNIS ROBOT SYSTEM

## GENERAL INSTRUCTIONS

The Newgy Table Tennis Robot System includes Robo-Pong models 540, 1040, and 2040. Upgrade kits are incorporated into the system to enable a customer to retain their investment in their robot and to add features and capabilities as needed. These upgrades consist of the Robo-Pong 540 Upgrade Kit to convert a 540 into a 1040 and the Recycling Net Upgrade Kit to transform a 1040 into a 2040. See page 18 for more information on these upgrades.

Robo-Pong robots require no assembly or tools. They are pre-assembled and factory tested before being packed and shipped. They only require a brief set-up before they're ready for play! The following quick set-up steps will assist you in properly setting up your robot.

If you purchased a 2040, a video is included that also explains set-up and operation. Additionally, the video includes some simple table tennis techniques for returning the different spins your robot can deliver (*also see page 8*). Please view the video first if you have a video player.

For maximum enjoyment of and benefit from your Robo-Pong, it's best to follow the simple set-up steps as outlined below or as shown in the video. Later chapters of

this OWNER'S MANUAL will discuss in detail robot operation, complete disassembly, maintenance, troubleshooting, accessories, parts replacement, service, and warranty. In general, instructions will apply to all models except when clearly designated by a caption, heading, or the following footnotes: <sup>1</sup>Robo-Pong 1040 only, <sup>2</sup>Robo-Pong 2040 only, or <sup>5</sup>Robo-Pong 540 only.

The ROBO-PONG TRAINING MANUAL in your robot package (for 2040 models sold from the U.S.) explains in detail table tennis strokes, spins, serves, footwork, and other techniques. It also tells how to use your robot for fitness training and as fun entertainment for kids and adults. In addition, there is a wealth of coaching articles and other information on our website at [www.newgy.com](http://www.newgy.com).

Your robot comes with a supply of Newgy 40mm Robo-Balls (for robots sold from the U.S.). Robo-Balls are specially selected for the best robot performance possible.

To order additional balls, the instructional manual, video, upgrade kits, or any other robot accessory or part, please contact Newgy Customer Service. Contact info is given on the front cover of this manual.

## QUICK SET-UP FOR ROBO-PONG 540

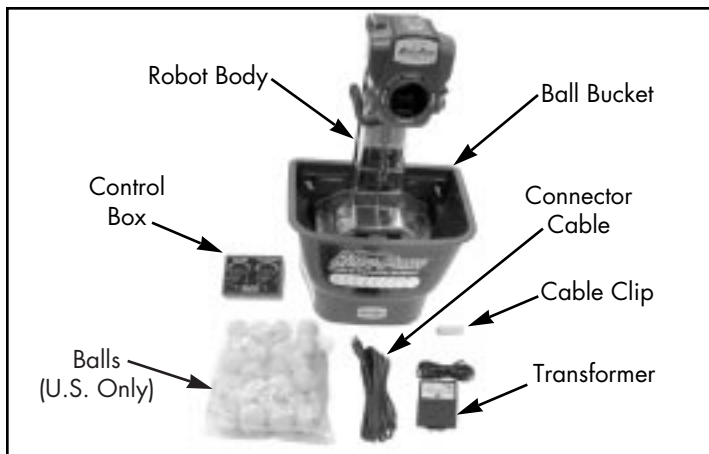

**1** **VERIFY ALL PARTS**  
Unpack all the parts and check that all parts are present. If unable to identify a part, look for a small silver label with the name of the part. If any part is missing, please contact Newgy immediately. You may want to keep your box and styrofoam pieces in case you ever need to ship your robot.

**2** **WASH BALLS, THEN PLACE IN BUCKET**  
Open the bag(s) of balls and wash them in lukewarm, soapy water. Then rinse in clear water and dry. Place the washed balls in the Ball Bucket. Other new balls you use should be washed and dried before placing them in the bucket. You may also include used balls with worn surfaces. **All balls must be the same size (38 or 40mm).**

**3** **VERIFY BALL SIZE SWITCHES**  
Make sure the Ball Size Switches are set to the size of the ball you are using. There are two switches, one on each side of the robot's head. If the ball is 40mm, it will have a "40" stamped on the ball; otherwise, it is a 38mm ball. If you need to adjust the Ball Size Switches, see page 10. **Do not mix ball sizes.**



**4** **ADJUST HEAD ANGLE**  
Loosen the Brass Knob on the right side of the robot (as you're facing it), and angle the head down as far as possible and then re-tighten. Verify that the word "topspin" is at the top of the ball discharge hole. (*See Figures 4, 5, & 7 on pages 7 and 8 for more info.*)



**5** **CONNECT CABLE TO ROBOT**  
Plug one end of the Connector Cable into the 5-Pin Connector on the back of the robot as shown. (*Also see Figure 17, page 13.*)



# 6

### POSITION ROBOT ON TABLE

Position the robot in the center of the table close to the endline as shown.

The robot's head should be in line with the centerline of the table (*Robot position 1, Figure 15, page 12*).



# 7

### ATTACH CABLE CLIP TO TABLE

Bring the free end of Connector Cable to the player's end of the table. Remove the protective backing from the bottom of the Cable Clip. Press it onto the side of the table about 12 inches from the end in a horizontal position. If you're right-handed, place it on the left side of the table. If you're left-handed, place it on the right side of the table. Open the clip and place the Connector Cable and the Transformer's cord inside the clip so approximately 12 inches of cable are free. Close the clip. Plug the Transformer into a suitable electric power source as printed on top of the Transformer. (*See Chart B, page 20.*)

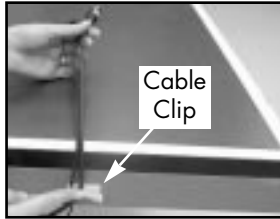

# 8

### CONNECT CABLES TO CONTROL BOX

Plug the Connector Cable into the 5-pin socket on the rear of the Control Box. Then insert the Transformer's pin into the adjacent Power Jack (*see Figure 2B, page 6*). Position the Control Box at the corner of the table (*See Figure 15, page 12*).

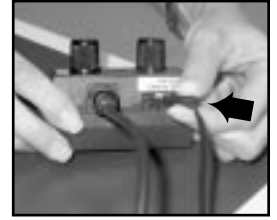

# 9

### GET READY TO PLAY!

With your paddle in your playing hand, turn the Ball Speed knob to 2-3 and the Ball Frequency knob to 4-5. It takes about 30 seconds for the balls to load up before the first one is delivered. To become more familiar with the controls and adjustments for your machine, read the OPERATION section of this manual starting on page 6.

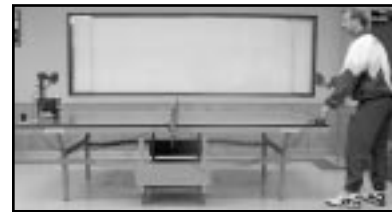

## QUICK SET-UP FOR ROBO-PONG 1040

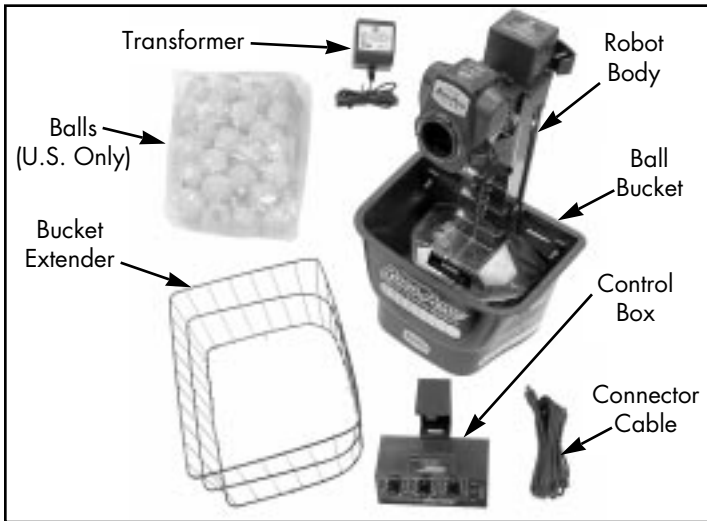

# 1

### VERIFY ALL PARTS

Unpack all the parts and check that all are present. If unable to identify a part, look for a small silver label with the part name. If any part is missing, please contact Newgy immediately. You may want to keep your box and styrofoam pieces in case you ever need to ship your robot.

# 2

### DETACH ROBOT BODY

Loosen the two Wing Nuts holding your robot body onto the Ball Bucket. Rotate the black, rectangular Clip Washers 180°. Pull the Robot Body off the bucket.



# 3

### ATTACH BUCKET EXTENDER

Slide the Bucket Extender onto the top of the bucket so that the hooks on the bottom of the Extender capture the top lip of the Bucket. Stop when the hook on the front of the Extender grabs the front lip of the Bucket. It may be necessary to lift the rear of the Extender over the Locating Tab protruding above the rear lip of the Bucket. Reattach the Robot Body to the Bucket by reversing step 2.

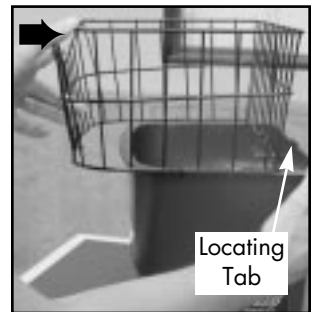

# 4

### FOLLOW STEPS 2-6 OF 540 SET-UP

Follow Steps 2-6 of the set-up instructions for Robo-Pong 540 on the opposite page and above.

# 5

### SET CONTROL LEVERS TO 3 & 4

Verify that the Oscillator Control Levers are in the 3 & 4 positions. If not, pick up slightly on the lever and swing it or the lever guard into the correct position. More info on oscillator adjustment is on page 9.



# 6

### CONNECT CABLES TO CONTROL BOX

Bring the free end of Connector Cable to the player's end of the table. Plug the Connector Cable into the 5-pin socket on the bottom of the Control Box. Then insert the Transformer's pin into the Power Jack of the Control Box (see Figure 1B, page 6).



# 7

### ATTACH CONTROL BOX TO TABLE

Place the Control Box on the side of the table about one foot from the end. If you're right-handed, place it on the left side of the table. If you're left-handed, place it on the right side. (See Figure 15, page 12 for more detail.) Plug the Transformer into any suitable electric power source. Transformer specifications are printed on top of the Transformer. (See Chart A, page 20.)

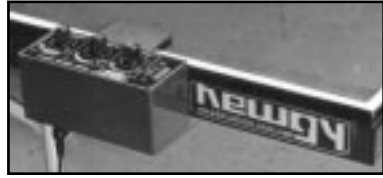

# 8

### GET READY TO PLAY!

Turn Oscillator Speed on and when the head aligns with the centerline of the table, turn Oscillator Speed off. Pick up your paddle, turn the Ball Speed knob to 2-3 and the Ball Frequency knob to 4-5. Turn the Power switch to "on" and get ready to return the ball. It takes about 30 seconds for the balls to load up before the first one is delivered. When you're ready for random delivery, turn the Oscillator Speed on and the balls will be randomly delivered across the entire table. To become more familiar with the controls and adjustments for your machine, read the OPERATION section of this manual starting on page 6.

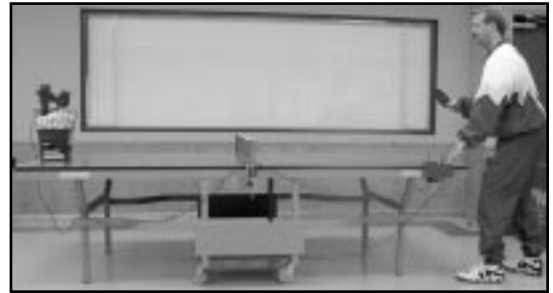

## QUICK SET-UP FOR ROBO-PONG 2040

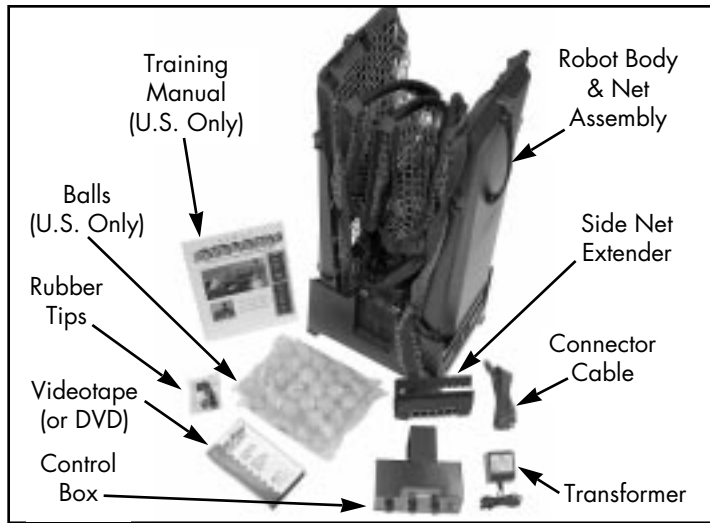

# 2

### PULL DOWN SUPPORT LEGS

Place the robot on the table with the open front side facing you. Pull the curved black metal support legs toward you.

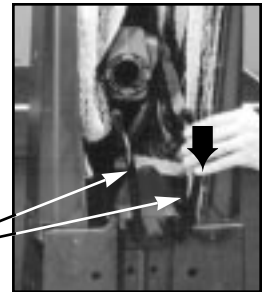

# 3

### SPREAD SUPPORT LEGS APART

Spread out the support legs to their fully open position.

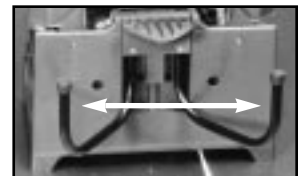

# 1

### VERIFY ALL PARTS

Unpack all the parts and check that all are present. If unable to identify a part, look for a small silver label with the part name. If a part is missing, please contact Newgy. You may want to keep your box and styrofoam pieces in case you need to ship your robot. If you purchased Pong-Master, check the photo below to verify all of its parts. In your Owner's Packet is a separate OWNER'S MANUAL for Pong-Master. That manual will tell you how to set up and operate Pong-Master. To help you separate robot parts from Pong-Master parts, the silver labels have "RP" before the part names for the robot and a "PM" before the part names for Pong-Master.



# 4

### JOIN NET SUPPORT TUBES

Turn the robot around 180° so the Net Support Tubes are now facing you. Grasp the second tube from the right and pull up, removing it from its storage hole. Place the bottom of this tube into the top of the first tube on the right as shown. Repeat on the left side.

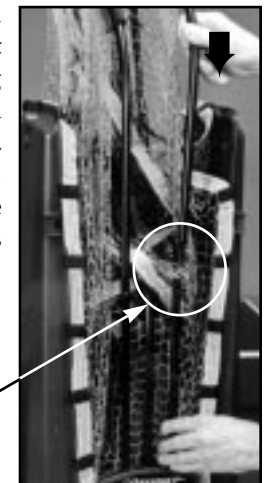

Joining Net Support Tubes

5

**LOWER BALL TRAYS**

Grasp one of the Ball Return Trays, lift straight up to unlock it, grasp the adjacent Net Support Tube, and slowly lower them into position. Be careful not to let the tray or support tube slam down. Repeat on the other side.

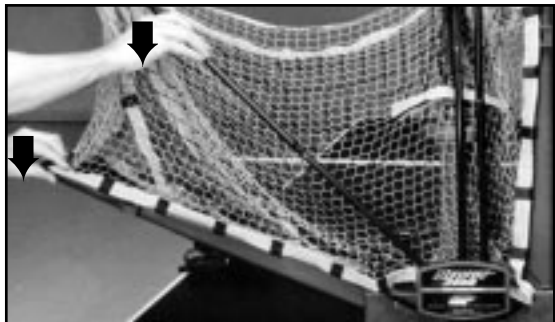

6

**ATTACH ROBOT TO TABLE**

Pick up the robot by the bottom of the Center Trough and secure it to the table by angling it downward and pushing it onto the end of the table. The Support Legs go underneath the table and the Front Support Plate sits on top of the table. The center of the Front Support Plate aligns with the centerline of the table. The robot will be held by its own weight. (See Figure 10, page 9 for more detail.)

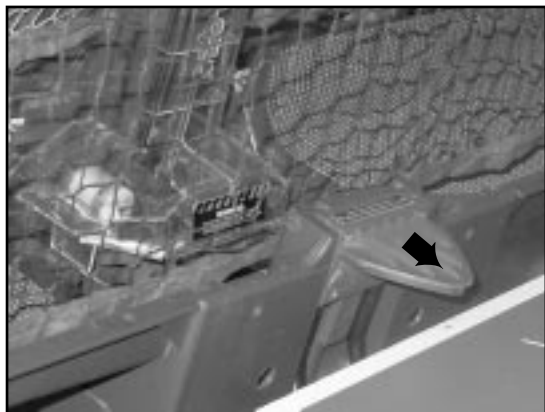

7

**FOLLOW STEPS 2-5 OF 540 SET-UP**

Follow steps 2-5 of the set-up instructions for Robo-Pong 540 on page 2, except after washing the balls, place them in the robot's Ball Return Trays instead of the Ball Bucket.

8

**ATTACH SIDE NETS**

Attach a Side Net to your table tennis net by slipping the slot in the Side Net Extender over the table's net and pressing down. Be sure Side Net follows and is directly above the sideline of the table. Repeat on the other side. (See page 14 for more details.)



9

**SET CONTROL LEVERS TO 3 & 4**

Walk around to the rear of the robot, open the slot in the back of the net by pulling the velcro apart and verify that the Oscillator Control Levers are in the 3 & 4 positions. If not, pick up slightly on a lever and swing the lever or lever guard into the correct position. (See page 9 for more details.)



10

**FOLLOW STEPS 6-8 OF 1040 SET-UP**

Follow Steps 6 to 8 of the set-up instructions for Robo-Pong 1040 on the opposite page.

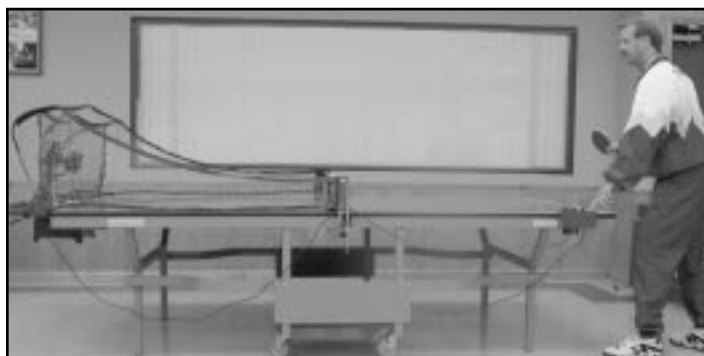

# OPERATION OF YOUR ROBOT

Your robot is extremely versatile and fully adjustable to suit a wide variety of playing abilities and styles. Ball speed, frequency, spin, trajectory, and placement can all be adjusted, as well as oscillator speed and range. The following section will explain the various controls and adjustments of your robot.

## CONTROL BOX (ALL MODELS)

The robot's motors are controlled electronically by the Control Box. Figures 1A and 1B illustrate the functions and controls for the 1040 & 2040 models. Figures 2A and 2B illustrate the functions and controls for the 540.

1. **POWER**—Used to turn the robot "ON" or "OFF".

2. **BALL SPEED**—Regulates the ball speed and spin. Higher settings increase the amount of spin and forward speed on the ball. On the 540, this control also functions as the on/off switch. See also *Ball Trajectory* on page 7.

3. **BALL FREQUENCY**—Regulates the time between

shots. Lower settings increase the time between shots. Higher settings decrease time between shots. Lowest setting at which balls will come out is approximately 2 (13 to 26 balls per minute). At a setting of 10, the robot delivers approximately 90 balls per minute for the 1040 & 2040 models and 60 balls per minute for the 540.

4. **OSCILLATOR SPEED**—Regulates the speed at which the robot head sweeps side to side. Higher settings make the head sweep faster. This control is also used to position the head in the desired direction when you want balls to be delivered to one spot. First set the control levers on the rear of the robot to positions 3 & 4 (see page 9). Turn Oscillator Speed on, and when the head reaches the desired position, turn it off. See also Figures 3A & 3B below.

**WARNING:** Use the Oscillator Speed control to make the robot head move sideways. **DO NOT** attempt to move the robot head sideways by hand. Doing so will likely result in broken parts and may void your warranty.

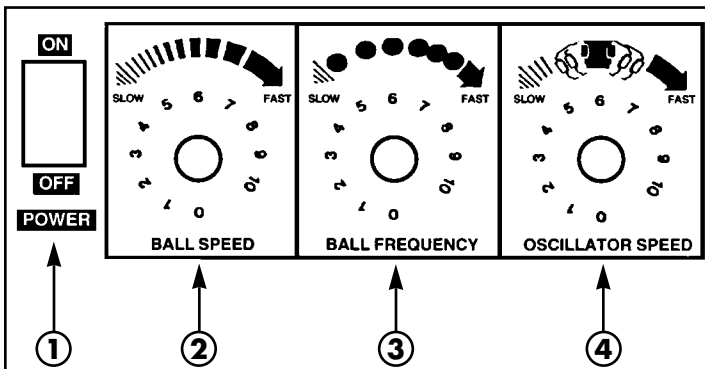

**FIGURE 1A** CONTROL BOX FOR 1040/2040 TOP VIEW

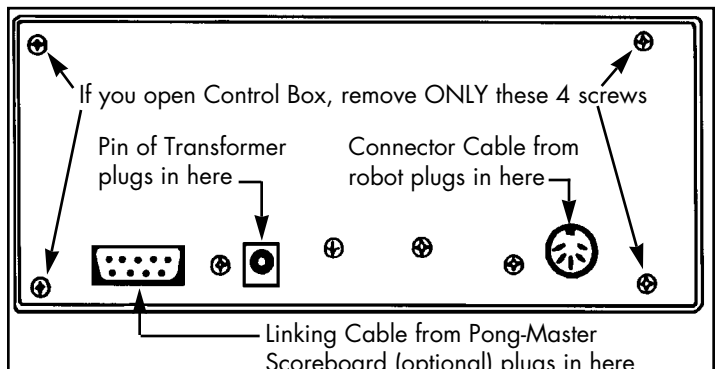

**FIGURE 1B** CONTROL BOX FOR 1040/2040 BOTTOM VIEW

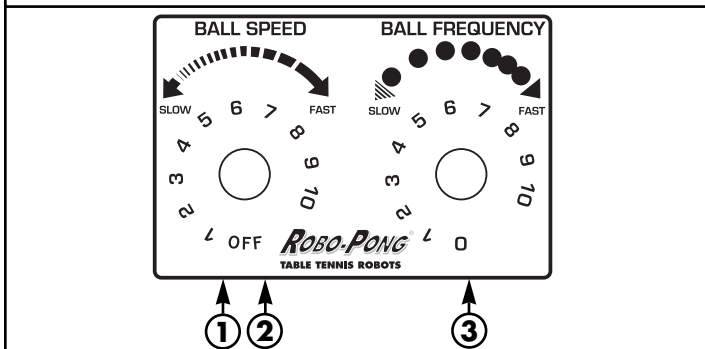

**FIGURE 2A** CONTROL BOX FOR 540 TOP VIEW

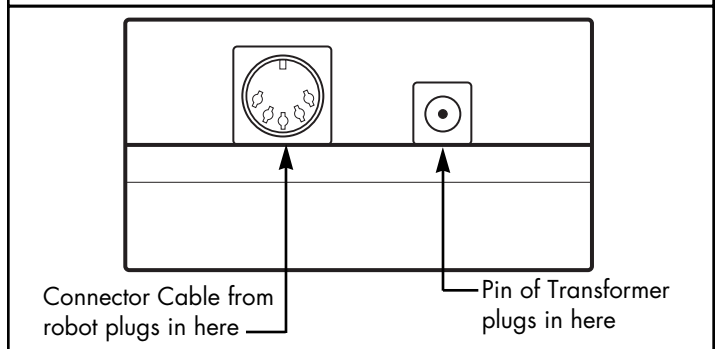

**FIGURE 2B** CONTROL BOX FOR 540 REAR VIEW

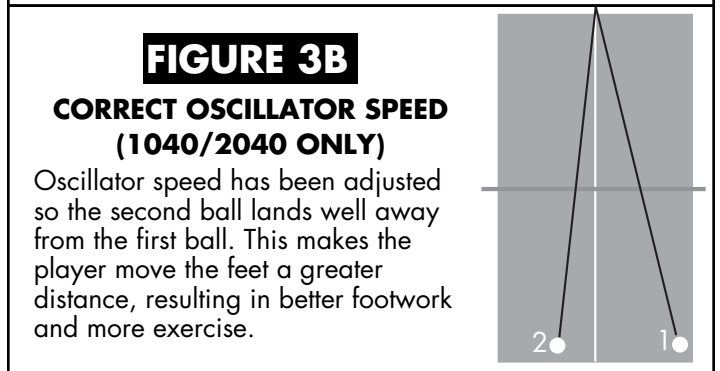
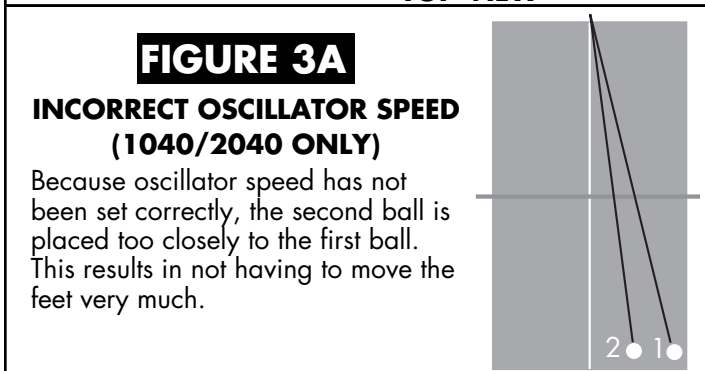

## BALL TRAJECTORY (ALL MODELS)

The trajectory of a ball is regulated by adjusting the angle of the robot head. The angle can be changed from low to high. At its lowest setting, the ball will be delivered so it first strikes the robot's side of the table, bounces over the net, and lands on the player's side of the table (just like a serve). At its highest setting, the ball will be delivered in a high arc over the net (like a lob return).

The trajectory is adjusted by loosening the Brass Knob on the right side of the robot head, tilting the head to the desired angle and then re-tightening the Brass Knob (see Figure 4). For reference, there are head angle indicators next to the Brass Knob (see Figure 5).

**WARNING: DO NOT** adjust the head angle when the head is moving side to side. Failure to follow these instructions will likely result in broken parts and may void your warranty.

The ball trajectory setting is directly related to the Ball Speed setting. When the head is set so the ball first strikes the **robot's** side of the table (robot "serving"—see Figures 6C & 6D), maximum Ball Speed is 3–5. As the Ball Speed is turned up, the head must be angled up to deliver the ball so it first strikes the **player's** side of the table (robot "returning"—see Figures 6A & 6B). As the Ball Speed is turned up even more, adjust the head angle down to prevent the ball from being thrown off the end of the table.

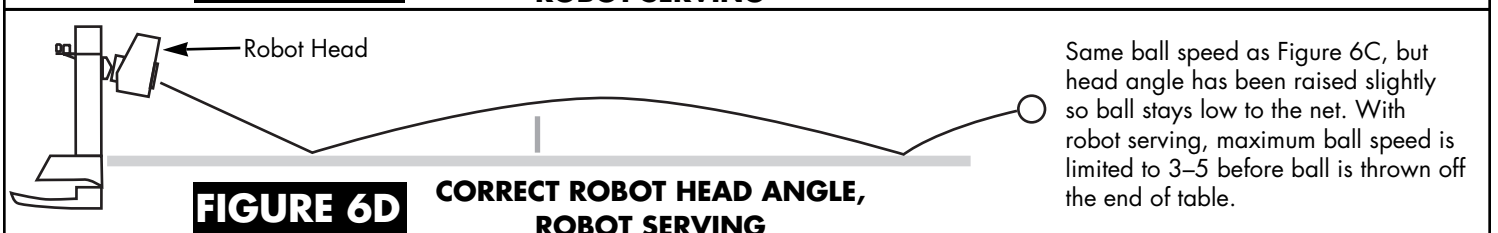
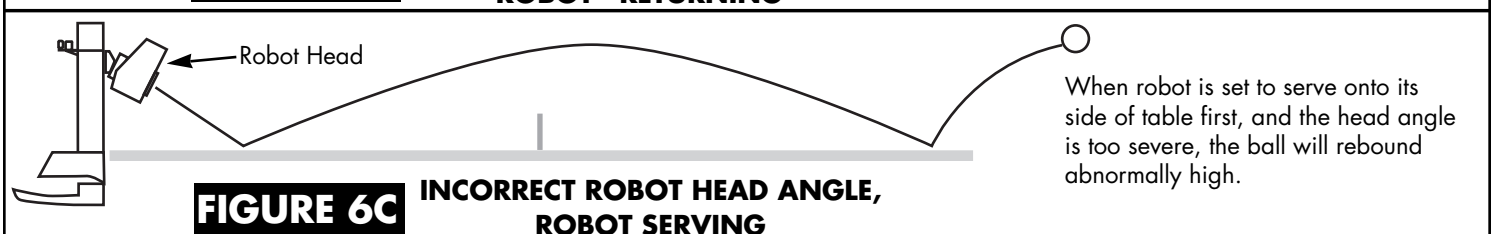
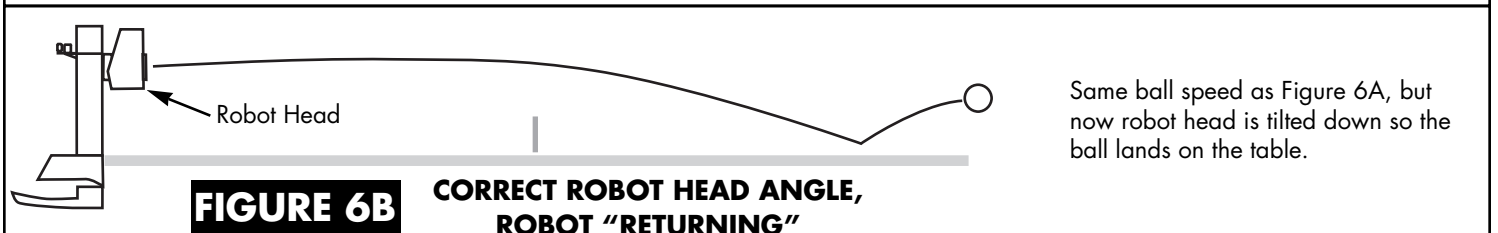
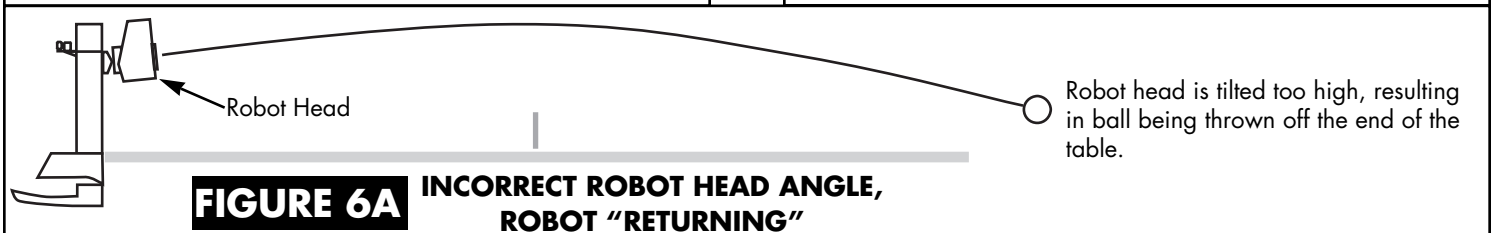
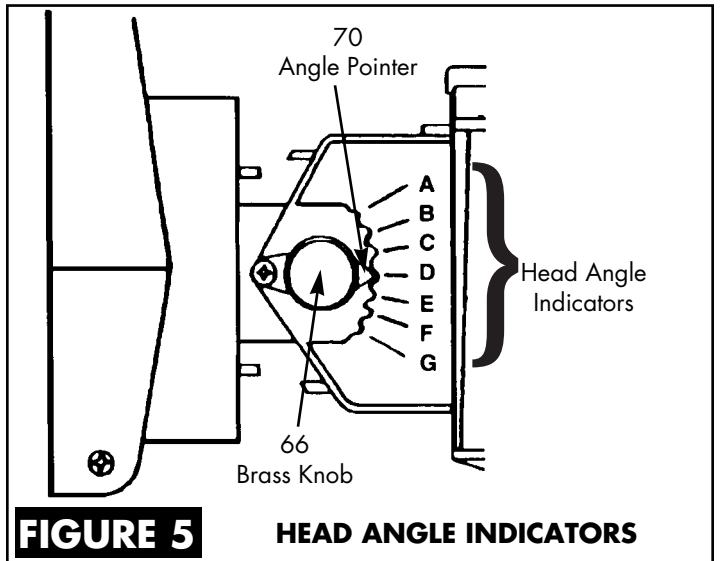
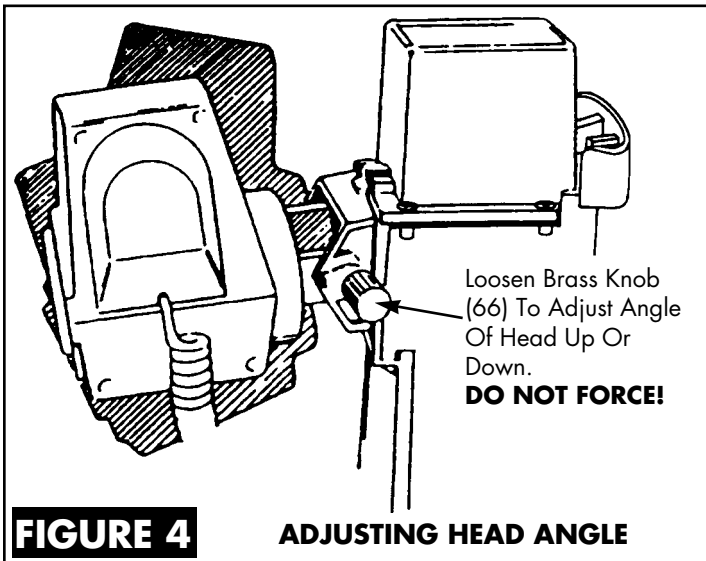

## BALL SPIN (ALL MODELS)

Robo-Pong robots are capable of putting any type of spin on the ball. Topspin, backspin, sidespin, and even combination spins can easily be selected. To change the spin, simply rotate the head of the robot until the desired spin is at the top of the Ball Discharge Hole (see Figure 7).

For combination spins, move the head until one of the rotational arrows is at the top of the Ball Discharge Hole. For instance, if the arrow between Topspin and Sidespin is selected, the robot will deliver a ball containing both topspin and sidespin. Likewise, if the arrow between Backspin and Sidespin is selected, the robot will deliver a combination backspin/sidespin ball.

Before discussing how to return spins, it's important to know that your robot simulates the play of a modern table tennis professional using inverted sponge rubber. With Robo-Pong robots, there is always some kind of spin on the ball. To learn how to produce your own spin and return an opponent's (or the robot's) spin, it is important to use the correct equipment—a quality inverted or pips out sponge rubber racket. Using old-style paddles such as hard rubber or sandpaper will make it more difficult to control spin.

Each spin has a different effect on the ball and how the ball reacts when you strike it with your paddle. Following are some brief pointers to help you return the different spins. More detail is available in Chapter 7 of the PLAYER'S INSTRUCTIONAL MANUAL which is included with your Robo-Pong 2040 if bought in the U.S., or available separately.

**The secret to returning spin is to angle your paddle correctly when contacting the ball.** Any spin can easily be returned if you angle your paddle properly. Set your paddle angle at the beginning of your stroke and maintain the same angle until your stroke ends. Avoid changing your paddle angle during your stroke. (See Figure 8.)

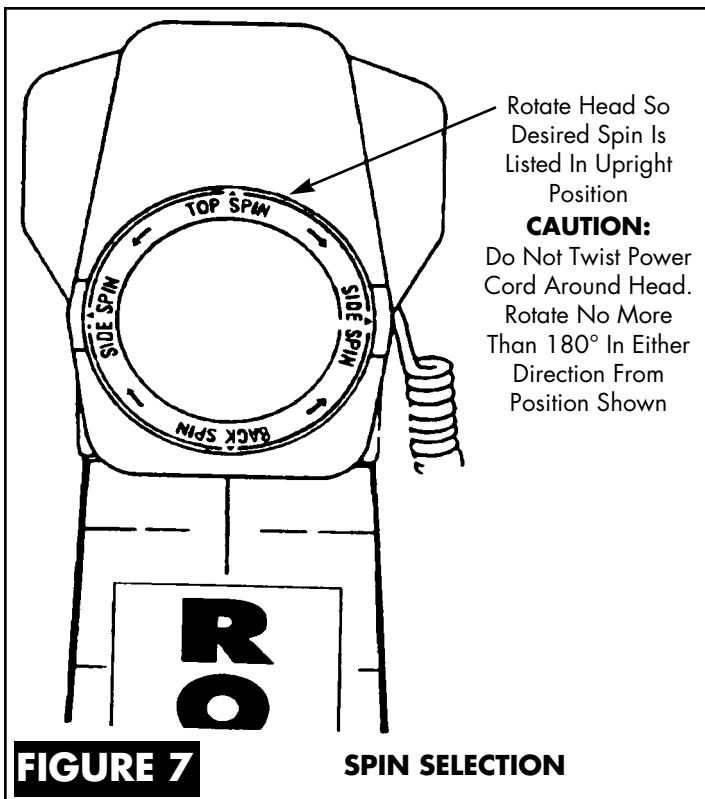

**Topspin** causes the ball to dip downward as it travels through the air. When you strike the ball with your paddle, it has a tendency to pop up high in the air. To compensate for topspin, angle your paddle face down as you stroke through the ball in a forward and upward direction. Contact the top surface of the ball. (See Figure 8A.)

**Backspin** causes the ball to rise upward and float as it travels through the air. When you strike the ball with your paddle, it has a tendency to go straight down into the table. To compensate for backspin, angle your paddle face upward as you push your paddle straight forward. Contact the bottom surface of the ball. (See Figure 8B.)

**Sidespin** makes the ball curve sideways through the air. Left sidespin makes the ball rebound off your paddle to your right; right sidespin to the left. To compensate for left sidespin, angle the paddle face to the left and contact the right side of the ball. To compensate for right sidespin, angle your paddle face to the right and contact the left surface of the ball. (See Figures 8C & 8D.)

**Combination spins** take on the characteristics of both spins, although to a lesser degree than the pure spins. To compensate for topspin/right sidespin, you must angle your paddle face down *and* to the right and contact the top left surface of the ball. Likewise, a backspin/left sidespin ball is best returned by angling your paddle face up *and* to the left and contacting the ball on its bottom right surface.

Spins are increased by turning up the Ball Speed knob on the Control Box. You increase both the speed and spin on the ball every time you turn up the Ball Speed knob. It is not possible to adjust Robo-Pong robots to deliver a slow ball with lots of spin, for instance. It is also impossible for Robo-Pong robots to deliver a no-spin ball. Additionally, since backspin causes the ball to rise, the maximum setting for Ball Speed when the robot is set on Backspin is approximately 4-5.

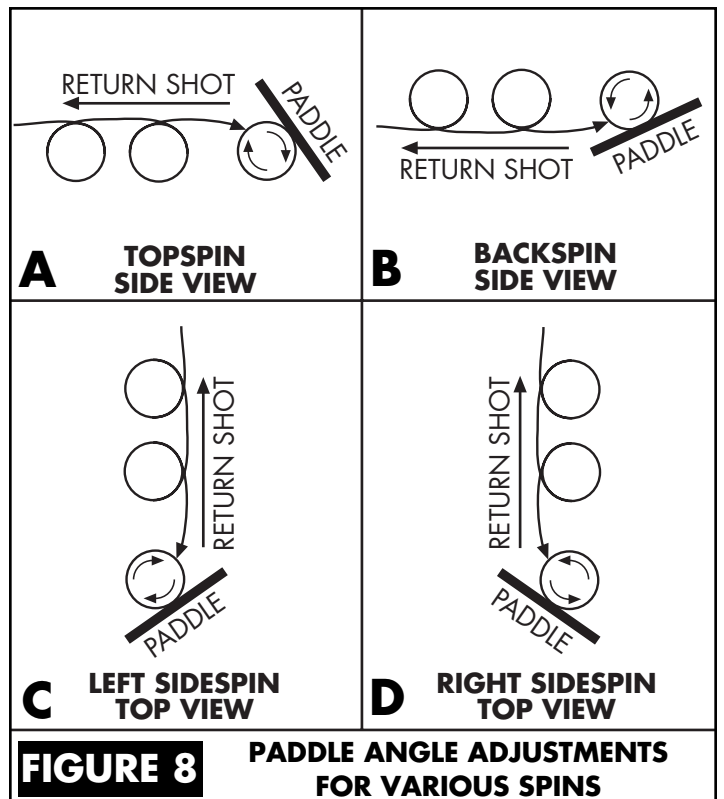

## OSCILLATION RANGE (1040/2040 ONLY)

Oscillation is the sweeping motion of the robot's head, enabling the robot to deliver consecutive balls to different spots on the table. Since Robo-Pong 540 has no oscillation controls, the information on this page does not apply to the 540. Furthermore, the oscillator ranges given on this page will apply to the 1040 and 2040 only when these models are positioned so the robot head is aligned with the centerline of the table (*Position 1 or 5, Figure 15, page 12*).

Models 1040 and 2040 have 8 selectable ranges (or zones) in which the robot head will sweep, delivering balls randomly within that zone. These zones are regulated by the Control Levers at the back of the robot (see *Figure 9*). Ranges are identified on a label at the top of the robot (see *Figure 10*). *Figure 10A* further clarifies these ranges.

Zones are selected by moving a Control Lever into the desired position as indicated by the number that appears through the hole in the Control Lever (see *Figure 9*). The Right Control Lever is restricted to positions 1, 2, & 3; the left to positions 4, 5, & 6. (Left and right designations for the robot are given as if you are facing the robot.)

To move a lever, lift it up with your finger, move it to the desired position, and then release it. If the lever will not move easily, pick up the lever and move the Control Lever Adapter instead. To access the Control Levers on the 2040, open the slot in the back of the net by pulling the velcro apart and reach with your fingers through the slot to touch the Control Levers (see *Step 9 on page 5*).

**WARNING: DO NOT** adjust the Control Levers while the head is moving. Also do not move both levers at the same time. Move one, then the other. Failure to follow these instructions will likely result in broken parts and may void your warranty.

Following is an explanation of each zone that can be selected as shown in *Figures 10 and 10A*:

**3,4**—Robot delivers balls across the entire table, from corner to corner (whole table).

**3,5**—Robot delivers balls from player's left corner to middle of right court ( $\frac{3}{4}$  table).

**2,4**—Robot delivers balls from player's right corner to middle of left court ( $\frac{3}{4}$  table).

**1,4**—Robot delivers balls from player's right corner to centerline ( $\frac{1}{2}$  table).

**3,6**—Robot delivers balls from player's left corner to centerline ( $\frac{1}{2}$  table).

**2,5**—Robot delivers balls from middle of player's right court to middle of left court ( $\frac{1}{2}$  table).

**1,5**—Robot delivers balls from middle of player's right court to centerline ( $\frac{1}{4}$  table).

**2,6**—Robot delivers balls from middle of player's left court to centerline ( $\frac{1}{4}$  table).

**1,6**—No oscillation. Place Control Levers in these positions whenever you transport or ship your robot, to prevent damage to the oscillator mechanism.

If you want stationary delivery, adjust the Control Levers to 3,4 and turn oscillator speed on. When the robot head points to the desired landing spot on the table, turn Oscillator Speed off. Failure to set the levers to 3,4 may result in "head drift", which causes the landing spot to change even though the oscillator is turned off.

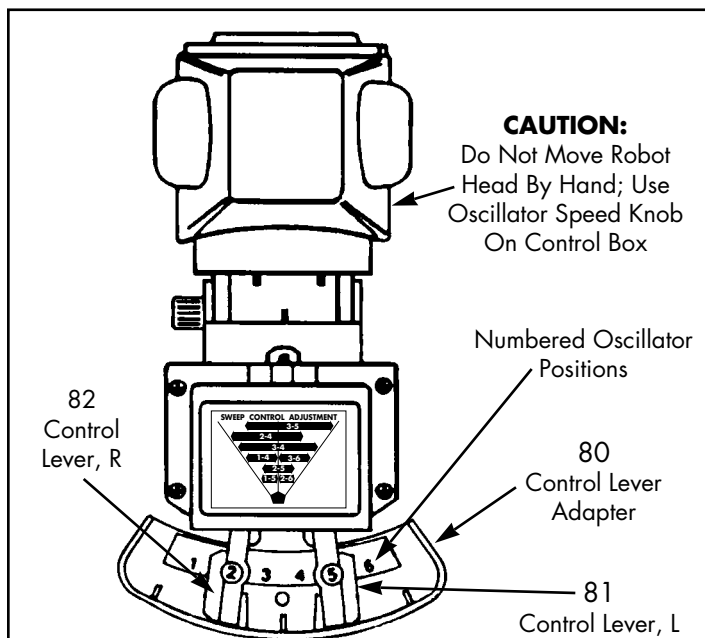

**FIGURE 9** OSCILLATOR CONTROL LEVERS TOP VIEW (1040/2040 ONLY)

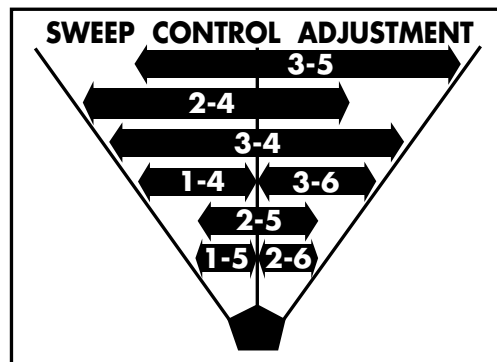

**FIGURE 10** SWEEP ADJUSTMENT LABEL (1040/2040 ONLY)

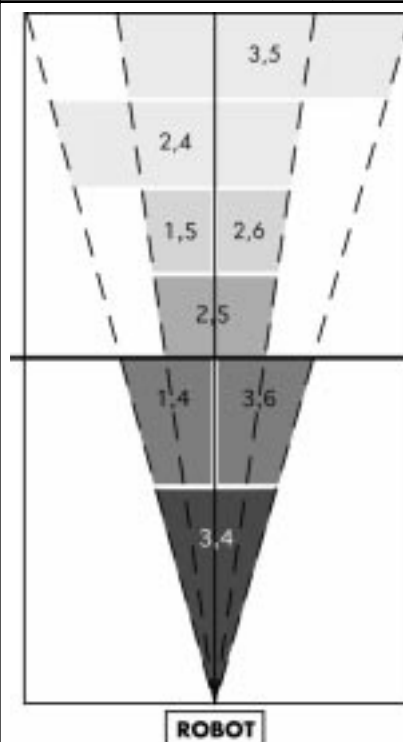

**FIGURE 10A** OSCILLATOR RANGES OF ROBOT WITH CONTROL LEVERS IN VARIOUS POSITIONS AND ROBOT ALIGNED WITH CENTERLINE OF TABLE (1040/2040 ONLY)

## BALL SIZE SWITCHES (ALL MODELS)

In October, 2000, the International Table Tennis Federation (ITTF) changed the size of the ball used in sanctioned tournaments from 38mm to 40mm in diameter. The traditional 38mm ball has been used since the early 1900's and is still available in many countries, including the U.S.. The ITTF requires that all 40mm balls be stamped with a "40" or "40mm" so they can be readily distinguished from 38mm balls. If you bought your robot in the U.S., it came with a supply of 40mm balls.

Robo-Pong models 540, 1040, and 2040 are all capable of using either the 38mm or 40mm ball. You must "tell" the robot what size ball you are using by setting the Ball Size Switches located on the robot's head. There is a switch on both sides of the head and it is extremely important that **both** switches be set correctly. Steps 1 and 2 below show how to set the switches and Steps 3 to 9 show what to do when changing from one ball size to the other.

### 1 SETTING SWITCH FOR 38MM BALLS

To set the switches for 38mm balls, hold the head steady with one hand while pulling the switch forward with your other hand until the switch snaps into the "38" position. Repeat on the other side of the head.



### 2 SETTING SWITCHES FOR 40MM BALLS

To set the switches for 40mm balls, turn power off and rotate the robot head so that "Topspin" is at the top of the discharge hole. Insert your thumb into the hole and press down on the rubber Friction Block just inside the opening. With your other hand, press the Ball Size Switch backward to "40" while continuing to depress the Friction Block. Repeat on the other side. **WARNING: DO NOT use undue force to move the switch to the 40 position. The Friction Block MUST be depressed before the switch can be moved easily.**

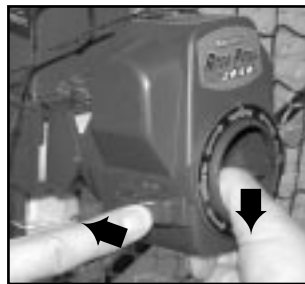

### 3 REMOVE BALLS FROM TRAY OR BUCKET

The following steps are necessary whenever changing from one ball size to the other. First, remove all balls from the Bucket (540 or 1040) or Trays (2040) and place them in a box where they will not get mixed in with balls of the other size. Then disconnect the Connector Cable from the back of the robot.



### 4 LOOSEN WING NUTS

Loosen the two Wing Nuts that hold your robot body onto the Ball Bucket or Center Trough. Rotate the black, rectangular Clip Washers 180°.

Clip Washer

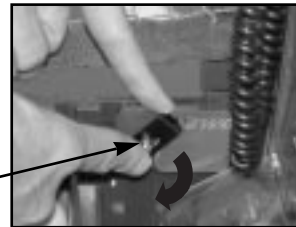

### 5 REMOVE ROBOT BODY

Pull straight up on the robot body to remove it from the Ball Bucket or Center Trough.

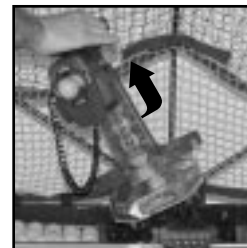

### 6 REMOVE CLEAR FRONT COVER

Place the robot body on your table. Pull the Clear Front Cover off by squeezing on the circular fingerholds on the sides of the cover with your thumb and forefinger, and then pulling up while squeezing. Pull the cover loose first at the top and then at the bottom. (See also Figure 23, page 15.)



### 7 REMOVE BALLS FROM INSIDE ROBOT

Remove all balls from inside the robot and place in the box with the other balls of the same size. Also gather up any balls that are on the floor or lying around loose in the playing area and place them inside the box too.



### 8 REATTACH ROBOT BODY

Reattach the Clear Front Cover (reverse of Step 6). Reattach the robot body, making sure that it fits fully down on the locating tab of the Center Trough or Ball Bucket. (See Figure 17, page 13.) Finally, re-tighten the Wing Nuts (reverse of Step 4).

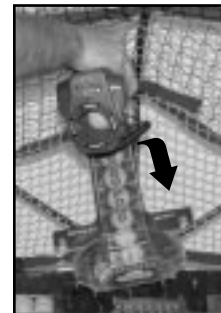

### 9 FINAL PROCEDURES

Place balls of the other size in the Ball Bucket or Ball Trays. (Be sure to wash and dry new balls before using them for the first time.) Select the proper setting for both Ball Size Switches (see Step 1 or 2, depending on ball size being used). Reconnect the Connector Cable (see Figure 17, page 13). Turn power back on and you're ready to play.

## WARNINGS

1. You must use all 38mm balls or all 40mm balls at one time. **Do not mix ball sizes.**
2. **Be sure BOTH switches are set to the same size.**
3. When swapping out ball sizes, remove all balls from the robot, including the ones inside the machine and those lying around the playing area, before re-loading the other-sized balls.
4. Immediately after adjusting the switch, depress and then release the Friction Block 2-3 times so it re-seats itself properly.
5. Be sure to wash and dry new balls before using them with the robot. New balls can cause multiple problems until they become "slick". (See Note 4, page 15.)
6. When switched to "40", if a 38mm ball gets mixed in with the 40mm balls, the 38mm ball will be ejected with very little forward speed.
7. When switched to "38", if a 40mm ball gets mixed in with the 38mm balls, the 40mm ball will either jam inside the robot's head or be ejected with an irregular trajectory. Damage may result.

### BALL DAMS (2040 ONLY)

Robo-Pong 2040 comes with a pair of Ball Dams. They serve three functions: (1) they keep balls inside the Center Trough when the robot is folded up, (2) they keep balls from entering the Center Trough when you want to remove the robot body, and (3) they serve as a ball gauge for determining if a ball is the proper size and whether it should be used in the robot.

The Ball Dams, when used for functions 1 or 2, fit into two retaining slots at the top of the Center Trough. When not in use, the Ball Dams fit into their storage slots on the side of the Center Trough (see Figure 11).

To use the Ball Dams when preparing the robot for storage or transport, remove the Ball Dams from their storage slots by pulling slightly up on the trays to reveal the storage slots (see Figure 13). Then push all the balls into the Center Trough and insert the Ball Dams into their retaining slots (see Figure 12). To use the Ball Dams for function #2, push the balls up into one of the Ball Return Trays and quickly insert the Ball Dam into its retaining slot before the balls can roll down into the Center Trough. The balls will be out of the way and you can easily loosen the two wing nuts and two clip washers, then pull up on the robot body to remove it (see Steps 4 & 5, opposite page).

The holes in a Ball Dam serve as a handy ball checking feature. One hole is 40mm in diameter and the other one is 38mm. The holes are marked with a "38" or "40" accordingly. These holes are used to test the roundness and size of balls you use in the robot. If you suspect a ball is out of round or too large, as indicated by balls jamming within the robot, insert the suspected ball into the ball checker hole. With your fingers, rotate it around inside the hole to check all possible diameters of the ball. The ball should have equal clearance through the hole on all diameters. The ball should barely fit through the hole without binding. It is also possible that a ball is too small. In this case, you will notice a considerable gap between the ball and the edge of the hole.

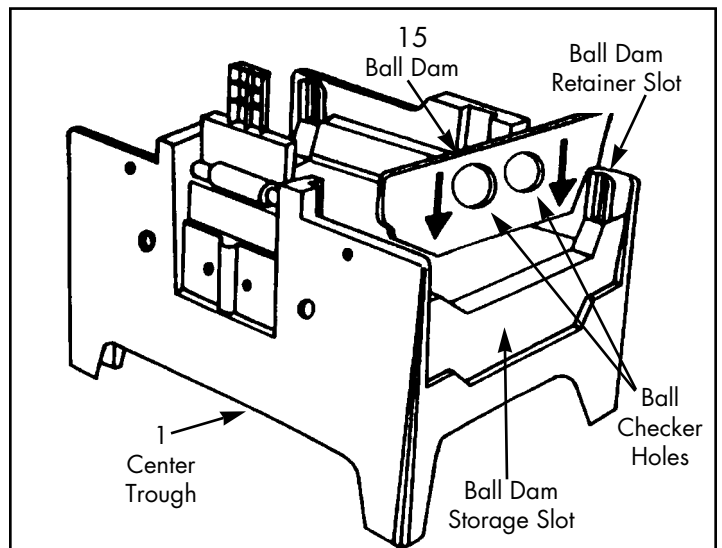

**FIGURE 11** BALL DAM & CENTER TROUGH (2040 ONLY)

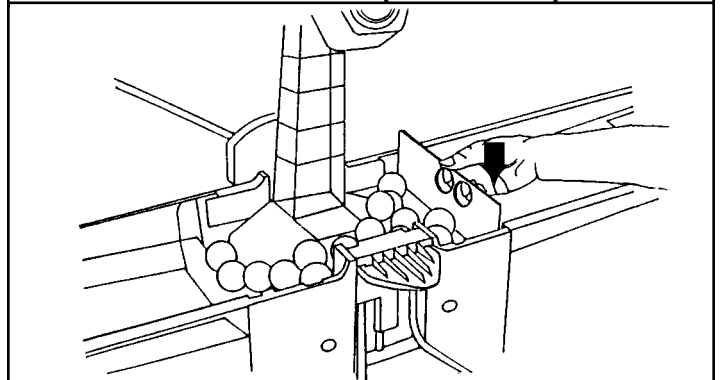

**FIGURE 12** INSERTING BALL DAM (2040 ONLY)

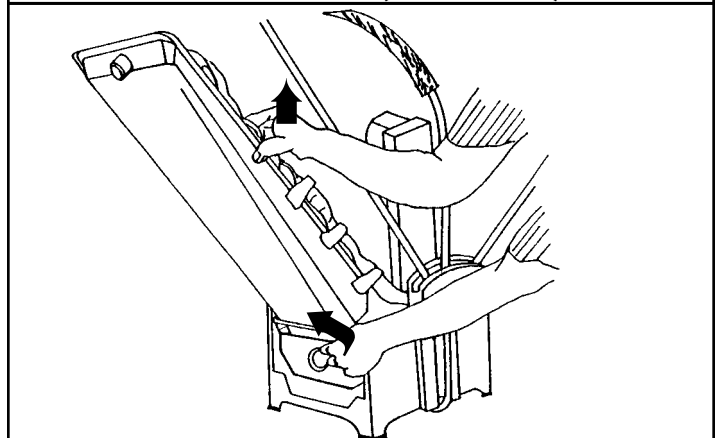

**FIGURE 13** REMOVING BALL DAM (2040 ONLY)

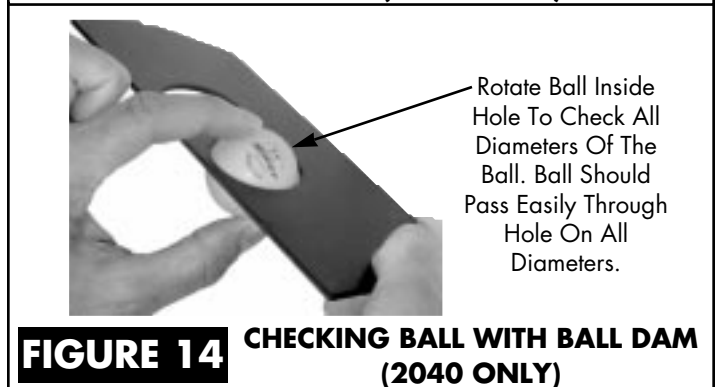

**FIGURE 14** CHECKING BALL WITH BALL DAM (2040 ONLY)

## POSITIONING YOUR ROBOT AND CONTROLS (ALL MODELS)

Robo-Pong robots are versatile in how they are positioned in relation to the table. The 540 and 1040 normally sit on top of the table as shown in robot positions 1–4 in Figure 15. They can also be mounted in the optional Robo-Caddy (see page 19) and placed behind the table like positions 5 & 6. The 2040 is typically mounted to the end of the table at position 5, but can alternatively be mounted in the Robo-Caddy just like the 540 and 1040.

Some positions offer certain advantages while other positions compromise some of the robot's functions. By placing the robot in various positions you can achieve a variety of angles and trajectories to simulate almost any type of shot you would encounter in a regular game. The following paragraphs explain this further.

**Position 1**—Robot positioned square to the table where the centerline and endline of the table meet. This is the only “on the table” position in which the 1040's oscillator ranges will be accurate (see *OSCILLATION RANGE*, page 9). Also this is the desired starting position when first setting up either the 540 or the 1040. In this position, the 540 will shoot straight down the centerline of the table.

**Position 2**—Robot positioned at the far left corner and angled cross-court. This position will skew the 1040's oscillator range toward the player's right side of the table. The 540 in this position would deliver the ball towards the player's right corner. This position would be the preferred direction when simulating typical right-handers' forehand to forehand rallies.

**Position 3**—Robot positioned at the far right corner and angled cross-court. Setting the robot in this position will skew the 1040's oscillator range toward the player's left side of the table. A 540 placed in this position would direct its shots to the player's left corner. Typical backhand to backhand play for right-handers would be ideally simulated with the robot in this position.

**Position 4**—A robot placed in this position has the advantage of offering slower and faster ball speeds because it is closer to the landing spot of the ball. At a Ball Speed setting of 0, the ball is very slow and with light spin, but is delivered deep on the player's end. At a Ball Speed setting of 10, the ball speed is very fast and simulates the angle from which a typical kill shot would be hit. However, the 1040's oscillator ranges are narrower than if the robot had been positioned at the endline like Positions 1–3.

**Position 5**—This is the normal position of the 2040 when it is attached to the end of the table, and its net system would function normally. The 1040 and 540 would have to be mounted in the Robo-Caddy to be in this position. Positioned here, the 2040's and 1040's oscillator ranges would be accurate.

**Position 6**—Mounted in a Robo-Caddy, all three models can be freely moved around in back of the table. The Robo-Caddy also permits lowering or raising the height of the robot. This is great for simulating deep shots such as chops, lobs and loops. However, the oscillator ranges for the 1040 and 2040 are not accurate and the 2040's net system is usually not effective at capturing balls when in this position. Additionally, you need to purchase a Connector Extension Cable (part# 2000-221) to extend the

length of the Connector Cable from 10 to 20 feet. This permits the Control Box to stay within reach of the player.

These positions are only a few of the ones possible, but they will give you a good idea of the pluses and minuses of placing the robot in a particular position.

**IMPORTANT NOTE:** *Even though the oscillator ranges may not be accurate as described on page 9 when the robot is in certain positions, you should be able, with experimentation, to find the correct settings for the Control Levers to permit ball delivery over any particular part of the table.*

Figure 15 also illustrates the ideal positions for the Control Box. If you're right-handed, Position A is the preferred location for the controls. If you're left-handed, Position B is preferred. Locating the controls in these suggested positions permits the controls to stay within easy reach of the player's free hand.

Since a player has a longer reach on the forehand side, it is suggested that you position your body as shown. The overwhelming majority of tournament level players use their backhand to cover about one-third of the table and their forehand to cover the other two-thirds of the table.

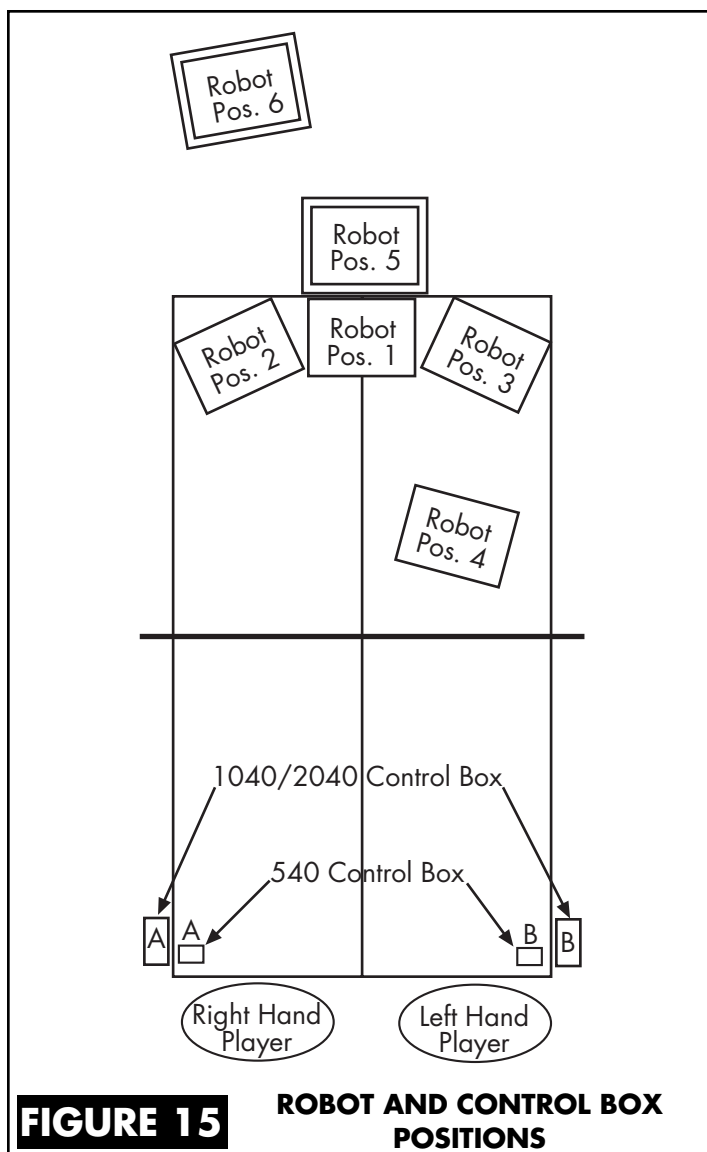

**FIGURE 15**

**ROBOT AND CONTROL BOX POSITIONS**

## MISCELLANEOUS ADJUSTMENTS (2040 ONLY)

### LEVELING ADJUSTMENT (2040 ONLY)

Robo-Pong 2040 is designed to sit level when attached to the table. In proper position (Figure 16), the CT Support Legs fit underneath the table and the CT Front Support Plate sits on top of the table. If the robot does not sit level, balls will not feed properly. If this condition occurs, it is necessary to make some leveling adjustments. The first adjustment is to level the table top by placing shims under the table legs until the table top is level.

If this does not cause the robot to sit level, then it will be necessary to make adjustments to the robot itself. The Support Legs come with 3 sizes of Rubber Tips and 4 rubber spacer-washers to accommodate different table top thicknesses, and cause the Center Trough to sit level. The Rubber Tips are marked on their top with the table thickness they are used with. The longest is used for 1/2" tops. The mid-size one is used on 3/4" tops and comes pre-installed. The shortest tip is used for 1" tops.

In addition to these different sized tips, there are 4 rubber spacer-washers which are used with the Rubber Tips for finer adjustments. Either one or two of these spacer-washers (depending on how much adjustment you need) are placed inside the Rubber Tips before the tips are placed on the end of the Support Legs.

Another reason why your robot may not sit level is that it is not properly seated on the locating tab. When seated correctly, the Support Flange of the Back Panel sits flush on the Locating Tab that protrudes from the top of the Center Trough (see Figure 17). Your robot serial number is located on top of this Support Flange.

**Tip:** If it is possible to adjust the level of the robot's half of the table independently from the player's half, you may choose to purposely give a slight slope to the robot's half so balls that end up on the table roll into the robot's trays. If you make the table unlevel, make sure the robot sits level by adjusting the Rubber Tips as described above. In this case, it may be necessary to use the Rubber Tip one size larger than normal to level the robot.

### ADJUSTING NET TENSION (2040 ONLY)

The Ball Return Trays should sit level with or just below the level of your table top. If the tension of the Main Net is too tight, the trays will be pulled up into a slight "V" shape with the top edge of the trays above the level of the table top. To correct this situation, you can loosen the adjustment straps shown in Figure 18 until the trays sit level. If this adjustment is insufficient, stretch the net by grabbing it with two hands and pull *gently* apart.

The Trap Net (the black net with large holes) slows down your returns so more of them are captured. The size of the holes is slightly smaller than the diameter of a ball. Hard hit shots force the ball through the net and the ball becomes trapped between the Trap Net and the Main Net. When slowly hit balls contact the Trap Net, they do not have enough force to go through the net, so they immediately drop down into the trays.

The Trap Net is normally hung loosely so as to increase its energy-absorbing capability. If you are practicing hard

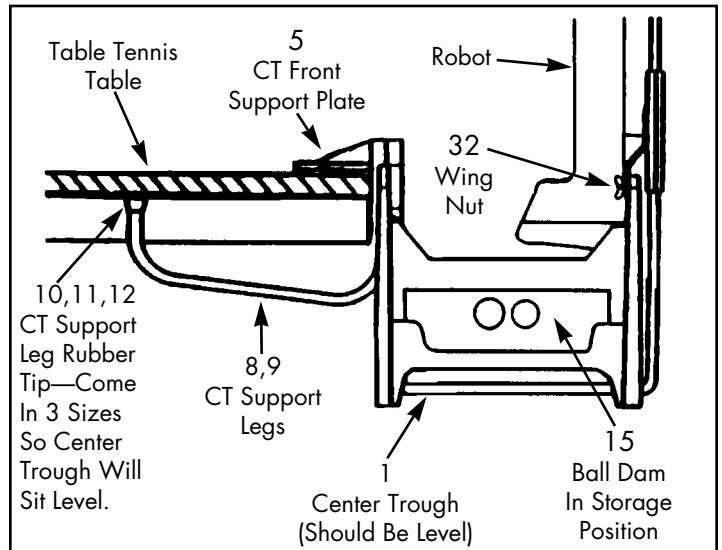

**FIGURE 16** CENTER TROUGH ATTACHMENT (2040 ONLY)

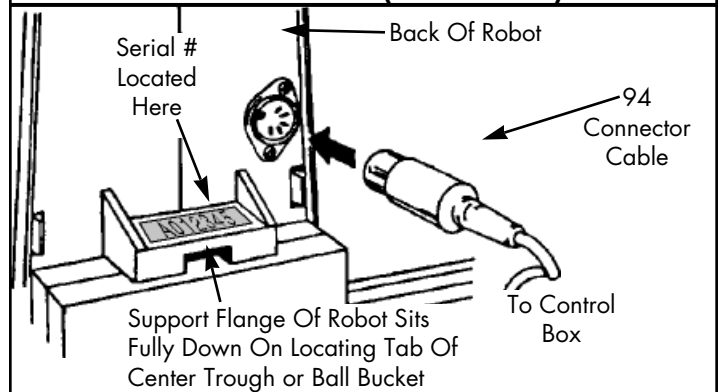

**FIGURE 17** SUPPORT FLANGE ALIGNMENT & SERIAL # (2040 ONLY)

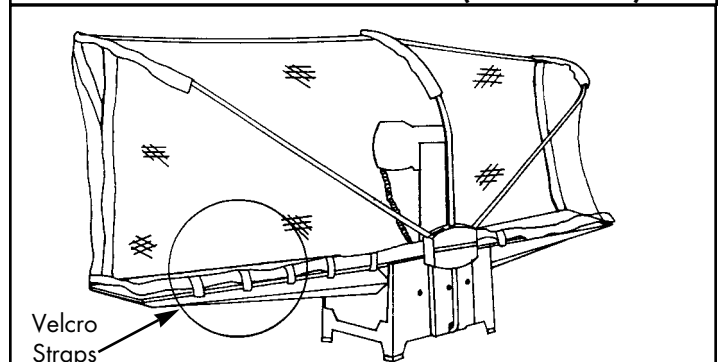

**FIGURE 18** ADJUSTING MAIN NET TENSION (2040 ONLY)

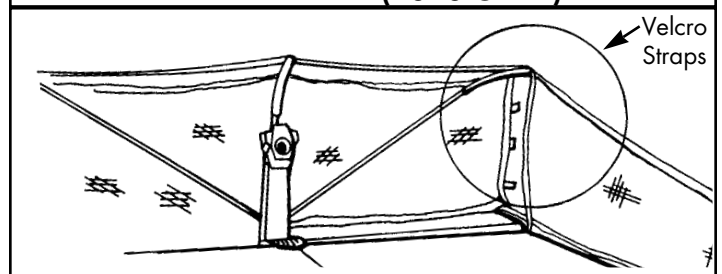

**FIGURE 19** ADJUSTING TRAP NET TENSION (2040 ONLY)

hit shots like smashes or fast loops, you may find that a tighter Trap Net captures more of your shots. The tension of the Trap Net is adjusted by tightening or loosening the velcro straps at the sides of the Trap Net (see Figure 19).

Attach the Side Nets to the table's net by slipping the slot in the Side Net Extender over the table net and press down until it stops (see Figure 20A). Remove the Extender by pressing the Extender forward with one hand while simultaneously pressing the table net backward with your other hand. Make sure that the entire height of the table net is pressed against the smooth edge of the Extender's slot (see Figure 20B). Otherwise, the toothed edge of the slot will grab the net and make removal more difficult.

Side Net Extenders come in pairs and mate with the Velcro Straps sewn to the ends of the Side Nets. The Extenders are not interchangeable due to how the Velcro is fastened to the Extender. One Extender will mate correctly to the Velcro sewn to the end of the right Side Net and the other Extender will mate correctly to the left Side Net.

By adjusting how a Side Net attaches to a Side Net Extender, you can tighten or loosen a Side Net. When properly tensioned and positioned, the Side Nets should slightly pull the table net to produce enough tension that the Side Net remains upright with little net sag. The Side Net should hang directly above the sideline of the table with very little or no gap between the bottom of the Side Net and the table surface (as shown in Figure 22B).

Figure 21 shows how to adjust Side Net Tension:

**21A**—This is the loosest setting. The Side Net's velcro is fastened to the first half inch of the Extender's velcro.

**21B**—This setting pulls the Side Net forward approximately 2 inches from the 21A setting. The front edge of the Side Net's velcro is even or slightly forward of the smooth edge of the Extender's slot.

**21C**—This setting pulls the net forward about 2 inches from the 21B setting. The Extenders have been switched so the left Extender is used on the right and right Extender is used on the left. The Side Net's velcro has been turned 180° so that what was the back edge is now the front edge.

**21D**—This setting is almost the same as 21C, but instead of the net being on the outside of the velcro, it has been turned inward so it is captured between the Side Net's velcro and the Extender's velcro. This setting pulls the net forward another 1/2" or so from the 21C setting.

21B, C, and D represent the tightest settings possible with the Side Net's velcro in a certain position. Of course, you may loosen the net from any of these three positions by moving the Side Net further back on the Extender.

When first used, the netting material is "taut". The material will "relax" over time by itself. If the net adjustments given in Figure 21 do not fix a problem, it may be necessary to manually "relax" the net.

Figure 22A illustrates this problem. Even though the length of the Side Net has been adjusted correctly, the bottom of the Side Net is too high, allowing a ball to roll underneath it. To correct, gently stretch the netting material directly above the problem area until it relaxes enough to where the bottom edge of the net is just above the table surface (see Figure 22B).

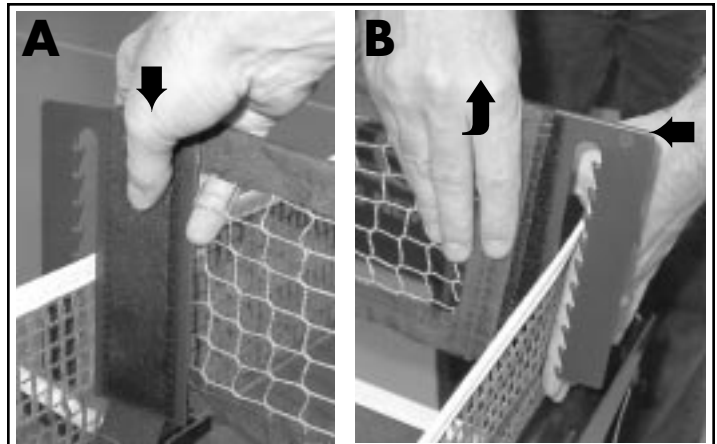

**FIGURE 20** ATTACHING AND DETACHING THE SIDE NET (2040 ONLY)

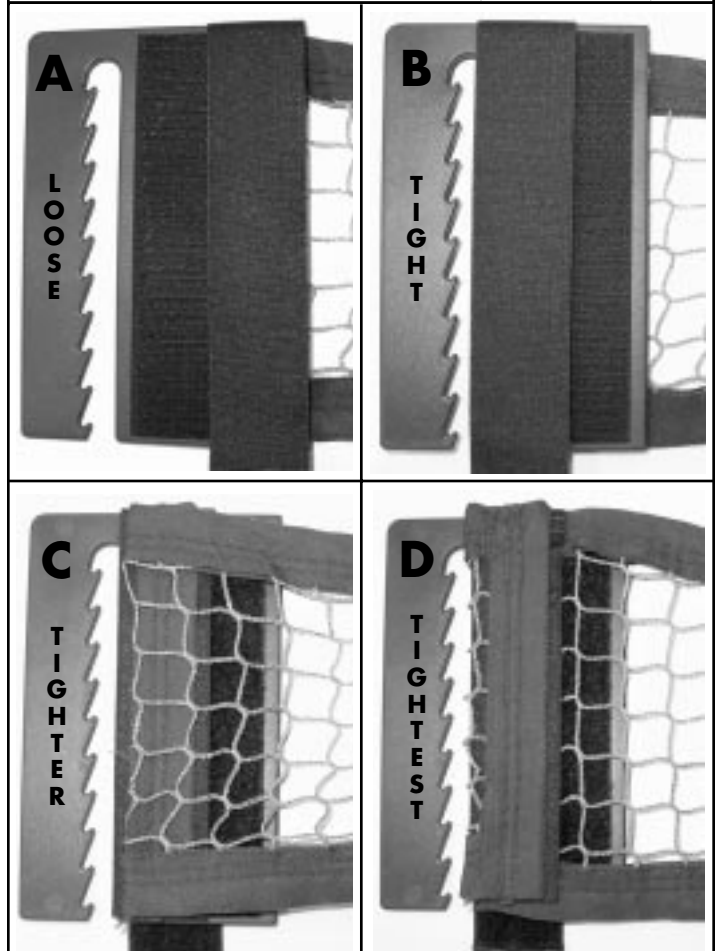

**FIGURE 21** ADJUSTING SIDE NET TENSION (2040 ONLY)



**FIGURE 22** IMPROPER/PROPER GAP FOR SIDE NET (2040 ONLY)

## IMPORTANT NOTICES (ALL MODELS)

**WARNING:** These points are vital for proper use and care. Failure to heed these points may cause damage to the robot.

1. Robo-Pong 2040, 1040, and 540 robots can use either the traditional 38mm ball or the newer 40mm ball. **You must change BOTH Ball Size Switches on the robot's head to match the size of the ball you are using. Do not mix ball sizes.** (See *BALL SIZE SWITCHES*, page 10 for more info.)
2. Before connecting your robot to power, be sure the transformer matches the power source in your area. Transformer specifications are printed on top of the transformer. (See *Chart A or B* on page 20.)
3. 2040 and 1040 robots are equipped with a special safety feature to warn you when ball jams occur. **Your Control Box emits a high-pitched squealing noise and shuts off the ball feed when it detects a ball jam!** Don't worry—your machine is operating the way it was designed to. This shut-off feature prevents damage to the ball feed gears and motor. Normally the solution is very simple. Turn off your Control Box, then agitate the balls where they feed into the machine. In particular, look for balls that have become stuck around the Ball Feed pickup mechanism. If agitating the balls doesn't fix the problem, then the problem is inside the robot.

To inspect inside the robot, remove the balls from the Bucket or the Trays and then remove the robot body by following Steps 3 to 6 on page 10. After removing the Clear Front Cover (see *Figure 23* on this page and *Step 6* on page 10.), look for balls that are cracked, dented, too large, or out-of-round. To test for ball roundness and correct size, read the last paragraph on page 11 and refer to *Figure 14*. Discard any bad balls.

4. New balls cause many ball jams. Before using new balls, including the ones that came with your robot (if applicable), be sure to wash them in lukewarm, soapy water. After washing, dry all balls with a clean, dry cloth before putting them in the Ball Bucket<sup>1,5</sup> or Ball Trays<sup>2</sup>. This will remove the powder that is on the surface of the balls. This powder causes excess friction, making the robot run erratically until the powder is removed.

After putting them in the Ball Bucket or Ball Trays, run the balls through the machine **at high frequency** by setting the Ball Frequency to 10, the Ball Speed to 3, the spin to "backspin", and aim the head at the middle of the table net. The balls will hit the table net, rebound, and automatically return into the net system (for robots with net systems).

For robots mounted in Ball Buckets, catch these balls by hand or in a tray or box, and return them to the Ball

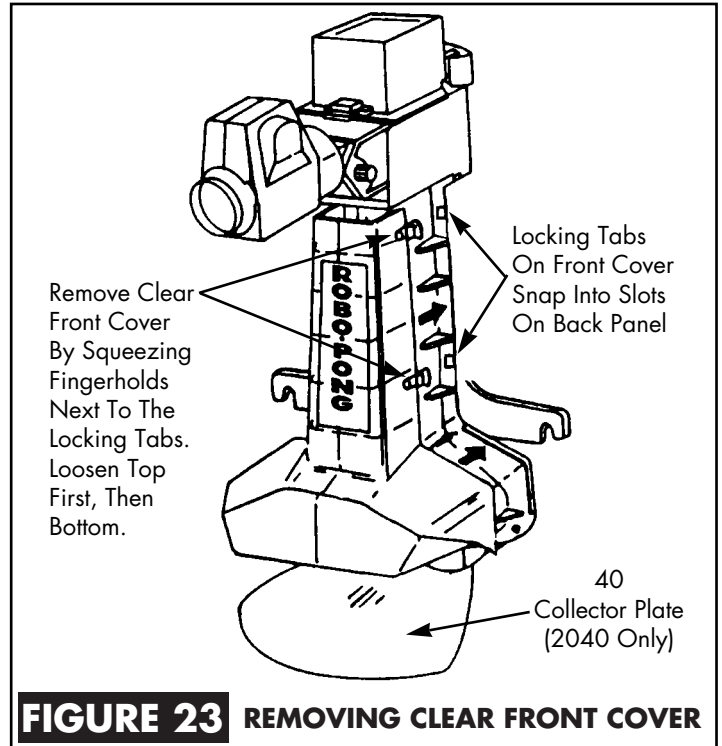

**FIGURE 23 REMOVING CLEAR FRONT COVER**

Bucket. This procedure will further "rub the balls down". Continue this rub down procedure for at least 5 minutes, then return to normal operation.

5. Use 3-Star balls or Newgy Robo-Balls for best performance. Most other brands of approved 1-Star, 2-Star, or 3-Star balls will also work. Avoid inexpensive non-graded and unapproved balls, especially those with rough seams. Well-worn balls work best.
6. When moving the 2040, always support it under the Center Trough. Do not carry it by the Tray Strap. The strap may loosen, causing you to drop your robot. If you want to carry it by the strap, replace the Rubber Strap with our optional Carrying Strap (see page 19).
7. Store unit indoors only. Do not leave the robot or Control Box outdoors. Avoid leaving unit in a hot car or trunk. Plastic parts can warp, crack, or melt if exposed to extreme temperatures. Do not use robot around sand. Sand will abrade plastic surfaces.
8. When lowering the trays on the 2040, don't let the trays fall down into place. Lower them gently. (See *Step 5*, page 5.)
9. Do not use sandpaper paddles with your robot. Sand can loosen from the paddle and end up inside the robot where it can abrade plastic surfaces and cause numerous other problems.

## TAKE DOWN, STORAGE, & TRANSPORT (2040 ONLY)

Robo-Pong 2040 can be easily taken down in less than 5 minutes. Your robot folds very compactly with all parts inside the robot. This model is also lightweight and very portable. Follow these steps to be sure all parts fold up correctly.

# 1

### PLACE SIDE NETS IN TRAYS

First, unplug the Connector Cable from the back of the robot. Then detach the Side Nets and place them in the trays.



# 2

### PLACE ROBOT ON CORNER OF TABLE

Remove the robot from the table and set it down on the corner of the table so you can easily access both the front and back of the robot.



# 3

### REMOVE BALL DAMS

From the front of the robot, raise each tray slightly and remove the Ball Dams from their storage positions. Don't raise too much or the balls will fall out! (See Figures 11 & 13 on page 11 for more detail.)

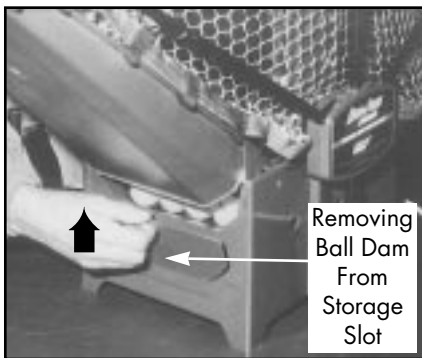

# 4

### INSERT BALL DAMS

Push the balls into the Center Trough and place the Ball Dams in their retaining slots. (See Figures 11 & 12 on page 11 for more detail.)

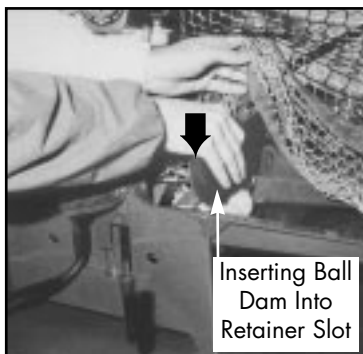

# 5

### PLACE CORDS IN CENTER TROUGH

Unplug the Transformer and Connector Cable from the Control Box and unplug the Transformer from the wall outlet. Coil both cords and place on top of the balls in the Center Trough. Place the Side Net Extenders on top of the balls. If you have Pong-Master, you may place its scoreboard and all of its cords on top of the balls as well.



# 6

### ADJUST HEAD ANGLE

Loosen the Brass Knob on the right side of the robot head and adjust the head angle to its highest position. Retighten the Brass Knob. (See Figure 4, page 7 for more details.)

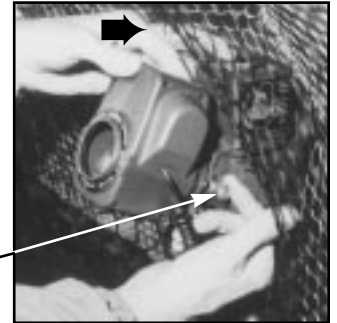

# 7

### PUT CONTROL BOX ON STORAGE POST

Hold the Control Box by its metal support bracket with knobs up. Raise the support leg assembly halfway and slide the Control Box onto its storage post between the Support Legs. Keep assembly raised to prevent Control Box from falling off the post.

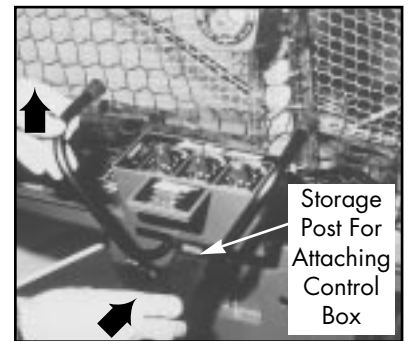

# 8

### FOLD BACK SUPPORT ASSEMBLY

Swing the Support Legs inward and fold the whole support leg assembly, with the Control Box attached, into the robot as shown. You may need to hold up the Trap Net while folding the assembly so it does not interfere with the folding process.

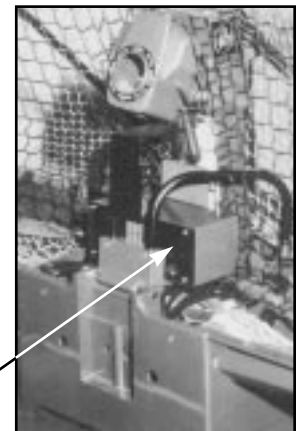

**9** Fold the Ball Return Trays closed by lifting until they lock into their vertical position.

**FOLD TRAYS UP**

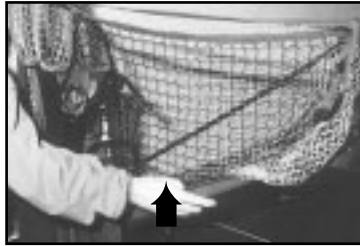

**10** From the back of the robot, detach the left and right Curved Net Support Tubes from their associated Straight Net Support Tubes. Place the curved tubes into their storage holes (2nd & 4th holes) on top of the Net Support Plate.

**PLACE NET TUBES IN STORAGE HOLES**



Separating The Upper And Lower Net Support Tubes

Net Support Plate

**11** When the robot is fully folded and with its components in their proper storage positions, all parts fit within the confines of the Center Trough and the Ball Return Trays.

**ROBOT PROPERLY FOLDED**



**12** Pull the tops of the Ball Return Trays together by attaching the free end of the Tray Strap to the top hole of the opposite tray. Should the anchored end of the Tray Strap ever come loose, it should be reattached to the bottom hole. It may be necessary to wet it before it will fit back in the hole.

**SECURE TRAY STRAP**



**WARNING:** Do not carry the robot by its rubber Tray Strap. This strap is not designed to support the weight of the robot. Replace the Tray Strap with the optional Carrying Strap (see page 19) if you intend to carry your robot by the strap.

**13** If you purchased the optional Robo-Tote carrying case (see page 18), your Robo-Pong 2040 will now fit inside the case. The carrying case protects the exterior of the robot during movement or storage and it comes with a backstrap for easy transport. The exterior pocket is used to store the Pong-Master targets (if you purchased that accessory). When inserting the targets into the pocket, target wires should be furthest down in the pocket to prevent the weight of the wires from bending the edges of the targets.

**PLACE ROBOT IN ROBO-TOTE**



**14** With your Robo-Pong 2040 inside its carrying case, it's ready to go anywhere you go. Carry it on your back, store it in a closet, or take it in your car to your friend's house! Your robot will be shielded from dust and all parts will be in one place when you're ready to set it up again.

**READY FOR STORAGE OR TRANSPORT**



# **NEWGY** Upgrades & Accessories

## **RECYCLING NET**

### **UPGRADE KIT**

Transforms your Robo-Pong 1040 into a 2040. Get ready for non-stop action. Play until you drop! Get true aerobic conditioning from your robot. Includes full net system, video, instructional manual, Collector Plate, and Side Net Extenders. Simple instructions make the conversion quick and easy.



## **ROBO-PONG**

### **540**

### **UPGRADE KIT**

Converts your Robo-Pong 540 into a 1040! More than doubles ball capacity and increases ball speed and frequency. Adds oscillation for side-to-side delivery. Includes Bucket Extender, full-size Control Box, oscillator controls, and more powerful transformer. Bucket Extender available separately.

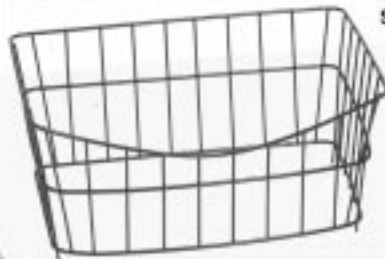

## **40mm**

### **UPGRADE KIT**

Easily and quickly retrofit your Robo-Pong 2000 to accept 40mm balls. Convenient ball switch lets you use either the traditional 38mm ball or the new international standard 40mm ball. Includes Wedge Filler for improved ball feed. No trade in required – you keep your old robot body.



## **PONG-MASTER**

### **INTERACTIVE ELECTRONIC GAME**

Plug Pong-Master in, and your robot becomes a Nintendo® style entertainment machine. Can you beat the robot at Pong-Master? It's tough. Vary the settings from beginner to world-class to test your accuracy, consistency, and ability to relax under pressure. Use it with the supplied targets for a fun, entertaining game or without the targets as a workout timer.

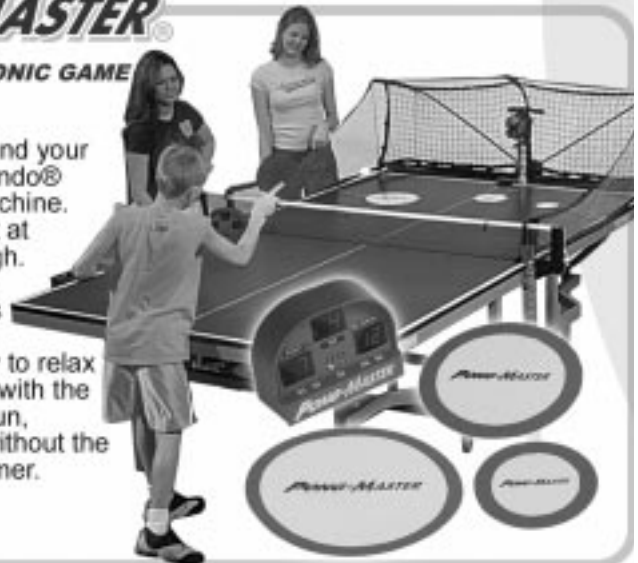

## **ROBO-TOTE**

### **CARRYING CASE**

Fit your model 2040 or 2000 robot into this carrying case and take it with you wherever you go. Protects your robot from dust or scratches. Will not fit other Newgy robot models. Includes adjustable carrying strap and pocket for Pong-Master targets or other items.



## **PONG-PAL**

### **"THE QUICKER BALL PICKER UPPER"**

Pick up balls easier and quicker with Pong-Pal. Even retrieve balls under tables or in other hard-to-reach places. Its unique two-piece design lets you carry it in your sport bag or Robo-Tote. Works with either 38mm or 40mm balls.





## Robo-Caddy

Easily control the robot's height, distance from table, and angle. Remarkable simulation of away-from-table shots like loops, lobs, and chops. Also use as a ball holder for multi-ball or serve practice. Fits all robot models. Connector Extension Cable is available separately and lengthens Connector Cable from 10 to 20 feet and is highly recommended.



## Ball Catch Net II

Captures and collects your returns for quick and easy manual ball recycling. Use with Newgy robots in ball buckets or for service practice. Captures and funnels balls into a bucket (not supplied). Optional Side Nets block angled shots and direct them into the main net. Assembly required.

## Tray Liners

These custom-fitted liners absorb ball impact and soften ball impact sound when attached to your model 2000 or 2040 ball trays. Also helps reduce effects of static. Priced per pair.



## Robo-Balls

Selected especially for use with Newgy Table Tennis Robots. Ideal for recreational play or multi-ball training. Durable. Long-lasting. Available by the gross (144) or Dozen (12) in orange or white 40mm (2-Star) or orange 38mm (1-Star).

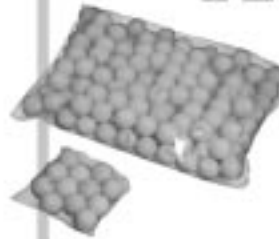

## Side Net Extender

Gives 1 to 2 inches of forward-backward adjustability in the length of the side nets on models 2040 and 2000. Prevents fraying of your table net. Allows quicker attachment to or removal from your table's net. Now included with all 2040's!



## Carrying Strap

This sturdy nylon strap replaces the standard rubber strap on models 2000 & 2040. Assures adequate strength to support the entire weight of your robot. Essential if you pick up your robot by the tray strap.



## Barrier

Use wherever you want to block table tennis balls from going, to separate a large room into individual courts, or to create aisles and queue lines. Easy to assemble and are 7' 8" long and 27" high. Made with a sturdy snap-together steel frame with fully enclosed end legs and reinforced corners for long-lasting durability. Feet rotate 90° for compact storage and transport.



## Applause Paddle

Excels at touch and control. Perfect for all-round play. Elastic inverted topsheet affords good spin to learn and execute high spin shots like loops and serves. Soft sponge rubber provides good speed and high control. Light weight and size of its head and handle are ideal for children, but still comfortable for adults. Straight handle with 1.9mm Newgy Omega rubber in red and black. Approved by USATT.



## Drive Cleaner

Special cleaning solution for the Ball Discharge Wheel and Friction Block in all Newgy robots. Increases grip and restores consistency to ball trajectory. Used and highly recommended by the Newgy Service Department. Can also be used as an excellent cleaner and grip restorer for rubber on your racket.



| ACCESSORY             | 540 | 1040 | 2040 |
|-----------------------|-----|------|------|
| Recycling Net Upgrade | •   | •    | I    |
| RP 540 Upgrade Kit    | •   | I    |      |
| Ball Catch Net II     | •   | •    |      |
| Robo-Tote             |     |      | •    |
| Pong-Master           |     |      | •    |
| Robo-Caddy            | •   | •    | •    |
| Pong-Pal              | •   | •    | •    |
| Robo-Balls            | •   | •    | •    |
| Carrying Strap        |     |      | •    |
| Tray Liners           |     |      | •    |
| I =Included           |     |      |      |

# MAINTENANCE STEPS & TRANSFORMER SPECS (ALL MODELS)

Robo-Pong robots are easy to maintain. The only maintenance that our robots require is an occasional cleaning. The Ball Discharge Wheel and Friction Block are especially prone to dirt build-up. Periodically inspect these parts and clean with Rubber Drive Cleaner (see page 19) and a cloth. One indicator that these parts are dirty is erratic delivery—balls are occasionally ejected sideways, down into the net, or popped up.

It's possible to clean these parts without disassembling the robot head. The following steps show how it is done using the Rubber Drive Cleaner and a cloth. This cleaner is terrific for removing dirt from rubber surfaces and restores the natural grip to these parts. If your fingers are too large to clean these parts through the discharge hole, you will need to disassemble the robot head. See Figures D & E on page 24 for disassembly instructions.

To reduce the amount of dirt that enters your machine, keep the table, balls, and playing area clean. Dust, pet hairs, carpet fibers, and other fibrous material can wrap around the drive pin and literally "strangle" the Ball Speed Motor to stop it from functioning. When wiping off the outside of your robot, use a damp cloth. Do not use any solvent based cleaner. Be careful not to get water on the motors, Control Box, or the 5 Pin Connector.

## 1

### REMOVE ROBOT BODY

First, remove the robot body from the Center Trough (2040) or Ball Bucket (540/1040). (See Steps 3, 4, & 5 on page 10.) Then lay it on a flat work surface.



## 2

### CLEAN FRICTION BLOCK

Make sure the word "Topspin" is at the top of the discharge hole. Wet your cloth with a small amount of Rubber Drive Cleaner. Insert the wet cloth into the discharge hole with your index finger and rub it forcefully over the curved rubber surface of the Friction Block (Key #77, Figure E, page 24). Using a dry section of the cloth, wipe the Friction Block lightly to remove any remaining dirt and dry it off.



## 3

### CLEAN DISCHARGE WHEEL

Rotate the head so the word "Backspin" is at the top of the discharge hole. To clean the Discharge Wheel, you must insert two fingers into the discharge hole. Wet a clean section of the cloth with the cleaner. Insert one finger into the hole to hold the side of the wheel and keep it from turning. Now, insert the wet cloth with your other finger and forcefully rub the rubber surface of the wheel. After you clean the initial exposed section of the wheel, rotate the wheel a little with your first finger to expose the next section of wheel for cleaning. Keep cleaning a small section of wheel at a time until you've cleaned the entire wheel. Then use a dry section of cloth to lightly dry off the wheel. Lastly reattach the robot body by reversing Step 1.



| Country & Part #      | Input Specs     | Output Specs               | Pin Shape |
|-----------------------|-----------------|----------------------------|-----------|
| USA<br>2000-222       | 120VAC,<br>60Hz | 12VAC<br>1200mA            |           |
| Europe<br>2000-232    | 230VAC<br>50Hz  | 12VAC<br>1600mA<br>19.2 VA | <br>      |
| Japan<br>2000-234     | 100VAC<br>50Hz  | 12VAC<br>1250mA            |           |
| China<br>2000-235     | 220VAC<br>50Hz  | 15VAC<br>1.25A             |           |
| Thailand<br>2000-236  | 220VAC<br>50Hz  | 13VAC<br>1250mA            |           |
| Australia<br>2000-238 | 240VAC<br>50Hz  | 12VAC<br>1.25A             |           |

\*Additional adapter (2000-233) required for UK and other British Commonwealth countries.

**CHART A**

### 1040/2040 TRANSFORMER SPECIFICATIONS

| Country & Part #     | Input Specs     | Output Specs   | Pin Shape |
|----------------------|-----------------|----------------|-----------|
| USA<br>540-222       | 120VAC,<br>60Hz | 12VDC<br>600mA |           |
| Europe<br>540-232    | 230VAC<br>50Hz  | 12VDC<br>600mA | <br>      |
| Australia<br>540-238 | 230VAC<br>50Hz  | 12VDC<br>600mA |           |
| Japan<br>540-234     | 100VAC<br>50Hz  | 12VDC<br>600mA |           |
| China<br>540-235     | 220VAC<br>50Hz  | 12VDC<br>600mA |           |

\*Additional adapter (2000-233) required for UK and other British Commonwealth countries.

**CHART B**

### 540 TRANSFORMER SPECIFICATIONS

# TROUBLESHOOTING GUIDE

- NOTES:**
1. There are no adjustments to any part, so if a faulty or worn part causes the robot to malfunction, replace that part.
  2. If you are not well-skilled at soldering, please send in your Control Box for service when soldering is indicated. Control Box parts are small and easily damaged. Improper soldering may void your warranty and service policy.
  3. If you open the 1040/2040 Control Box, unscrew **ONLY** the 4 corner screws. **DO NOT** remove the 4 screws in the middle. (See Figure 1B, page 6 for more details.)
  4. If the suggestions below do not help, please consult the troubleshooting section of our website at [www.newgy.com](http://www.newgy.com). It is updated periodically and will be more current than the information given below.
  5. The following solutions will apply to all models of Newgy Robots, except if marked with the following footnotes:  
<sup>1</sup>Robo-Pong 1040 only, <sup>2</sup>Robo-Pong 2040 only, <sup>5</sup>Robo-Pong 540 only.

## NO POWER PROBLEMS

### 1. PROBLEM

*No robot functions work and Power Switch on Control Box does not light up when turned on.*

#### SOLUTIONS

- A. Make sure transformer is plugged securely into a power outlet. Verify there is power in the outlet. Check that transformer input (on top of transformer) matches local electrical specifications. See Chart A or B, pg. 20.
- B. Check that the pin of the transformer cord is plugged securely into the Power Jack of the Control Box.
- C. Transformer is defective. Test for proper output with a voltmeter. If defective, replace.
- D. If Control Box has been knocked off the table, a break may have been created on the circuit board. Inspect and resolder any broken connections. Break is usually where the Power Jack is soldered to the circuit board.
- E. Verify that wires are properly attached to the Power Switch. Red wire should be closest to "off". Brown or white wire should be attached to the middle terminal. Black wire should be closest to "on".<sup>1,2</sup>
- F. Power Switch is bad. Replace.

### 2. PROBLEM

*No robot functions work or only work intermittently, and the Power Switch<sup>1,2</sup> lights up when turned on.*

#### SOLUTIONS

- A. Make sure Connector Cable is securely plugged in at both ends.
- B. Check fuse in Control Box. If blown, replace.<sup>1,2</sup>
- C. Fuse holder is not making good contact with the fuse. If loose, tighten; if defective, replace.<sup>1,2</sup>
- D. Bridge Rectifier is bad. Especially indicated if fuse keeps blowing after power is turned on. Replace.<sup>1,2</sup>
- E. Defective Connector Cable. See Solution 14A.

## BALL FEED/FREQUENCY PROBLEMS

### 3. PROBLEM

*Robot will not pick up balls.*

#### SOLUTIONS

- A. Pong-Master Scoreboard (an optional accessory) is controlling Ball Feed. Turn Scoreboard off.<sup>1,2</sup>
- B. Ball jam. See Problem 18.
- C. Ball Feed Motor is not running. See Problem 14.
- D. Ball Feed Motor runs backward. See Problem 13.
- E. Ball Feed transfer gears and/or Main Gear are damaged or assembled incorrectly. See Figure J, page 25 for correct assembly. Replace gears with stripped teeth or other damage.

- F. Pickup fingers are broken or loose. See Figure J, page 25. If loose, tighten; if broken, replace.
- G. If Control Box emits a high-pitched squeal when power is turned on, even if Connector Cable (and Linking Cable from Pong-Master Scoreboard, if applicable) is unplugged from the box, the U4 chip or 12V Relay on the circuit board is defective. Replace.<sup>1,2</sup>
- H. If problem occurs only at low ball frequency, spray inside Ball Feed Motor with tuner lubricant/cleaner.
- I. Ball Feed Main Gear is frozen to the shaft of the BF Mountng Plate. Replace gear and plate.

## BALL SPEED/DISCHARGE PROBLEMS

### 4. PROBLEM

*Ball speed seems to be slower than when new.*

#### SOLUTIONS

- A. Incorrect Transformer. Check Chart A or B, page 20.
  - B. Hair or fibers are entwined around drive pin of Ball Speed Motor. Remove Ball Discharge Wheel and inspect at base of brass shaft on the motor. Clean, if necessary. See Figures D & E, page 24.
  - C. The brass shaft on the Ball Speed Motor is loose. The Ball Discharge Wheel is screwed onto this shaft and then the shaft is permanently pressed onto the motor's drive pin. It cannot be reattached. Replace the motor. Test by holding the rubber wheel with a finger and then turn power on and adjust Ball Speed to 10. If you hear the motor spinning while you are holding the wheel stationary, then the brass shaft is loose. If the motor does not spin, then shaft is securely fastened.
  - D. Ball Discharge Wheel and/or Friction Block are worn. Replace both parts. See Figures D & E, page 24.
  - E. Ball Speed Motor needs lubricating. Spray inside motor with an electrical contact cleaner/lubricant.
  - F. Friction Block (FB) is not moving freely. Test by pressing FB down with your thumb and visually check to see if FB tabs are returning to the top of their slots. If FB is hanging up in its travel, remove FB and smooth its tabs and/or sides by filing. Also, clean out FB tab slots in the head housings. Replace FB if necessary. May also be caused by overtorquing of robot head screws. If loosening these screws frees up FB travel, replace left head housing. See Figure E, page 24.
  - G. Potentiometer, Voltage Regulator, and/or Bridge Rectifier inside the Control Box are bad. Replace.<sup>1,2</sup>
  - H. Balls are too small. Check with Ball Dam. See page 11.
- ### 5. PROBLEM
- Robot picks up balls, but balls just fall out of discharge opening instead of shooting out.*

## SOLUTIONS

- A. If using 38mm balls, be sure both Ball Size Switches are in the "38" position. If using 40mm balls, and switches are set to "40", check balls to be sure a 38mm ball is not mixed in with 40mm balls. See pages 10 & 11.
- B. Ball Speed Motor is not running. See Problem 14.
- C. Friction Block is missing or not functioning properly. See Solution 4F.
- D. Ball Discharge Wheel has come off. Reattach. See Figure E, page 24. See also Solution 4C.
- E. Ball Speed Motor is running backwards. See Problem 13.
- F. Balls are too small. Check with Ball Dam. See page 11.

### 6. PROBLEM

*Robot shoots erratically. Some balls delivered high, others low or off to the side or ball speed changes without the Ball Speed knob being turned.*

## SOLUTIONS

- A. If using 40mm balls, check to be sure both Ball Size Switches are in the "40" position. If using 38mm balls, and switches are set to "38", a 40mm ball may be mixed in with your 38mm balls. See pages 10 & 11.
- B. Friction Block is dirty, worn or defective. If dirty, clean; otherwise, replace. See cleaning procedures on page 20 and Figure E, page 24. Also see Solution 4F.
- C. Ball Discharge Wheel is dirty, worn, out of round, cracked, or loose. If loose, tighten; if dirty, clean; otherwise, replace. See cleaning procedures on page 20 and Figure D, page 24.
- D. Ball Speed Motor mounting screws are loose. Tighten. See Figure D, page 24.
- E. Slots in Robot Head Housings for Friction Block tabs and/or 2mm spacers of the Ball Size Switches are worn. Replace housings. See Figure E, page 24.
- F. Ball Discharge Spring is defective. See Solution 18F.

### 7. PROBLEM

*Robot shoots more than one ball at a time.*

## SOLUTIONS

- A. Ball Discharge Spring has come off or is damaged. Replace. See Figure E, page 24.
- B. Using new, dirty, low quality, or oversized balls. Wash and dry new or dirty balls. After washing new balls, be sure to use rub down procedure described in Note 4 on page 15. Check balls with a Ball Dam to be sure they are the correct size and roundness. See page 11.

---

## OSCILLATOR PROBLEMS<sup>1,2</sup>

---

### 8. PROBLEM

*Oscillator motor runs, but head does not move.<sup>1,2</sup>*

## SOLUTIONS

- A. Control Levers are set to 1,6. Reposition. See page 9.<sup>1,2</sup>
- B. A gear post, lever, or the Control Lever Adapter has broken. Replace. See Figures B & G, pages 24 & 25.<sup>1,2</sup>
- C. Oscillator is not assembled correctly. Be sure top pin of Pivot Guide is inserted inside the hole on the bottom of the Oscillator Motor Cover and that the bottom pin of the Pivot Guide is in the corresponding hole of the Upper Guide. See Figure G, page 25.<sup>1,2</sup>

### 9. PROBLEM

*Oscillator operates, but Oscillator Control Levers jump out of place while oscillator is running.<sup>1,2</sup>*

## SOLUTION

- A. Control Levers are bent or cracked. Levers can sometimes be bent back into shape when softened by heating. Otherwise, replace. See Figure G, page 25.<sup>1,2</sup>

### 10. PROBLEM

*Oscillator operates, but motion is jerky and/or straining noises are heard.<sup>1,2</sup>*

## SOLUTIONS

- A. Oscillator Motor Cover is pressing down on the Control Levers, restricting their movement. Remove cover and file or scrape away a small amount of the bottom edge of the cover that is directly above the levers. See Figure G, page 25.<sup>1,2</sup>
- B. Rough mold parting seams on the top and/or bottom of Oscillator Pivot Guide. Smooth seams with a file or sharp knife. See Figure F, page 25.

### 11. PROBLEM

*Robot does not deliver the ball all the way to either the left or right corner of the table when spin is set to straight topspin or backspin, Control Levers are set to positions 3 & 4, and robot is in position 4 or 5 (Figure 15, page 12).<sup>1,2</sup>*

## SOLUTIONS

- A. See Solutions 8B, 8C, 9A, 10A, & 10B.<sup>1,2</sup>
- B. Make sure fit of Control Lever Adapter to Pivot Guide is very tight. If loose, replace Control Lever Adapter and/or Pivot Guide. See Figure G, page 25.<sup>1,2</sup>
- C. Be sure Clear Front Cover is properly attached.
- D. Plastic pins on top and bottom of Oscillator Pivot Guide are not straight and exactly perpendicular to the top and bottom surfaces. If either pin is crooked, replace Pivot Guide. See Figure G, page 25.
- E. Defective Friction Block. Replace. See Figure E, pg. 24.
- F. If problem persists after eliminating all other solutions, you may intentionally twist the robot and/or mount the robot off-center towards the problem corner.

### 12. PROBLEM

*Robot head drifts away from intended direction when oscillator is turned off.<sup>1,2</sup>*

## SOLUTION

- A. Set Control Levers to positions 3 & 4. See page 9.<sup>1,2</sup>

---

## GENERAL MOTOR PROBLEMS

---

### 13. PROBLEM

*Ball Speed Motor or Ball Feed Motor runs backward.*

## SOLUTION

- A. The 5 Pin Connector is incorrectly wired or the motor connections are reversed. In either case, switching the wires on the motor will correct the problem. See Figures E & J, on pages 24 & 25.

### 14. PROBLEM

*One or two motors don't run, but the others run normally.*

## SOLUTIONS

- A. One or more wires inside the Connector Cable are broken. Examine the cable by plugging it in and turning on the power. Adjust knob controlling the inoperative motor to 10, other knobs to 0. Then twist, turn, push, and pull a small section of cable at a time trying to get the broken wires inside the cable to make contact with one another. If the inoperative motor suddenly starts running, you have found the break. Also cable can be checked with a voltmeter. Replace.

- B. Check the 5-Pin Connector to see if two of the terminals are touching or if a wire is not soldered securely to its terminal. If so, carefully bend the terminals apart to keep them from touching or resolder the connection. See Figure I, page 25.
- C. A wire to the problem motor is unattached. Reattach.
- D. Wires attached to motor are shorting each other out. Bend terminals apart so wires don't touch each other.
- E. If the problem is either the Ball Feed or Oscillator Motor<sup>1,2</sup>, check the nylon transfer gears connected to the motor for obstructions or wear. Clean and relubricate **sparingly** with a light grease. Replace any gears with worn teeth. See Figures B & J, pages 24 & 25.
- F. Motor is "frozen" (especially likely if robot has not been used for awhile or is stored in a damp or humid environment). Turn knob controlling the inoperative motor to 10. Give the steel gear or rubber wheel at the end of the motor a turn with your fingers. If the motor was frozen, motor will start spinning. Lubricate motor with an electrical contact cleaner/lubricant.
- G. Motor is defective. The motor can be tested by touching the motor terminals with the posts of a 9-volt battery. Before testing, disconnect any gears that are connected in sequence to the motor. If the motor does not run from battery power, it must be replaced.
- H. The Voltage Regulator and/or the Potentiometer inside the Control Box that governs the inoperative motor has gone bad. Replace or send in for repair.<sup>1,2</sup>
- I. If Ball Feed Motor, and above solutions don't work, Relay Switch on circuit board may be bad. Replace.<sup>1,2</sup>
- J. If none of the above solutions work, the problem is likely a short or bad component inside the Control Box. Replace or send in for repair.

**15. PROBLEM**

*A motor runs, but does not change speed when the knob on the Control Box is turned.*

**SOLUTIONS**

- A. If all motors run at top speed, check that the wires inside the Control Box that connect the Potentiometer Circuit Board to the Main Circuit Board are plugged in securely. Red wire goes to the #1 terminal.<sup>1,2</sup>
- B. See Solution 14H.

**16. PROBLEM**

*Turning a knob on the Control Box affects a motor other than the one the knob normally controls.*

**SOLUTIONS**

- A. See Solutions 14A & 14B.
- B. Voltage Regulators inside Control Box are shorting across each other. Insulator Pad must be between the Voltage Regulators and the metal bottom of the Control Box. Voltage Regulator Bracket must not be contacting the leads of any two Voltage Regulators.<sup>1,2</sup>
- C. If turning the Oscillator Speed up causes Ball Speed and Frequency to slow down and the Power Switch light dims, the Circuit Board Brackets have scratched the traces on the Circuit Board. Replace brackets with insulated brackets available free from Newgy.<sup>1,2</sup>

**17. PROBLEM**

*All motors run slow.*

**SOLUTIONS**

- A. Be sure you are using the correct transformer. Check your Transformer against Chart A or B, page 20.
- B. Bridge Rectifier inside Control Box is bad. Replace.<sup>1,2</sup>

---

**BALL JAMS**

---

**18. PROBLEM**

*Balls jam inside the machine. Ball jams are normally indicated by a squealing noise from the Control Box.*

**SOLUTIONS**

- A. See Solution 6A.
- B. Using new or very dirty balls. The tacky finish on new balls or the dirt on dirty balls creates excess friction as the balls move through the robot. As the finish wears off or the dirt is removed, there is less friction created. Follow directions in Note 4 on page 15 for washing and "rubbing down" new or dirty balls.
- C. Oversize, irregular, or out-of-round balls. Check the balls using the ball checker holes in the Ball Dams<sup>2</sup>. Discard any balls that do not pass easily through this gauge. Avoid any balls that have a rough seam even if they pass the ball gauge test. See page 11.
- D. Dented or cracked balls. Anytime balls jam, check to be sure none of them get dented or cracked; otherwise, those balls can cause additional jams. Ball denting may also be caused by build-up of dirt on the Friction Block and/or Ball Discharge Wheel. Periodically inspect these parts, and if necessary, follow cleaning instructions on page 20.
- E. Foreign objects or loose parts in the ball feed path. Remove the Clear Front Cover (*Figure 23, page 15*) and inspect for objects that are preventing the Ball Pickup Wheel from turning or balls from sliding up the ball channel. Also check inside the robot head. Reattach any loose parts or remove any foreign objects.
- F. Worn or defective Ball Discharge Spring. Open the robot head and inspect the back surface of the Ball Discharge Spring for wear. Replace if any flat shiny surface is found or the spring is otherwise defective. This spring should be completely round with no flat spots. See Figure E, page 24.
- G. Ball Speed Motor runs backward. See Problem 13.
- H. Restricted ball feed channel. Occasionally the walls of the ball feed channel may warp inward enough to keep balls from moving easily upward. Remove the Front Cover and while holding a known good ball (as tested per Figure 14, page 11) slide the ball up and down the ball feed channel to verify that it does not hang up. If it does, it is possible to warm the walls with a hair dryer and carefully bend the walls apart at the restricted area to increase the clearance. See Figure A, page 24.
- I. Short inside Connector Cable causes the Jam Alarm in the Control Box to activate. Replace Connector Cable.
- J. See Solution 3E.

<sup>1</sup>Robo-Pong 1040 only

<sup>2</sup>Robo-Pong 2040 only

<sup>5</sup>Robo-Pong 540 only

# EXPLODED VIEWS, DISASSEMBLY, AND REPAIR

- NOTES:**
1. Refer to the following drawings when disassembling or assembling the robot. The key numbers used to identify the parts correspond to the key numbers on the Parts List on pages 26 & 27.
  2. There are no adjustments to any robot parts. If there is a faulty or worn part that causes the robot to malfunction, that part must be replaced. Your robot is designed to be easily serviced and repaired.
  3. Use grease sparingly on the gear trains connected to a motor since excess grease will get on other parts of the robot and the balls, and will attract dirt to the gears, causing clogs.

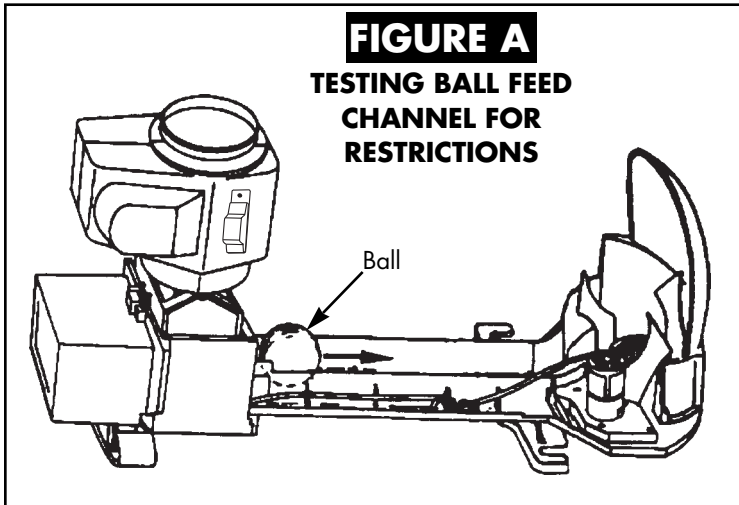

**FIGURE A**  
TESTING BALL FEED  
CHANNEL FOR  
RESTRICTIONS

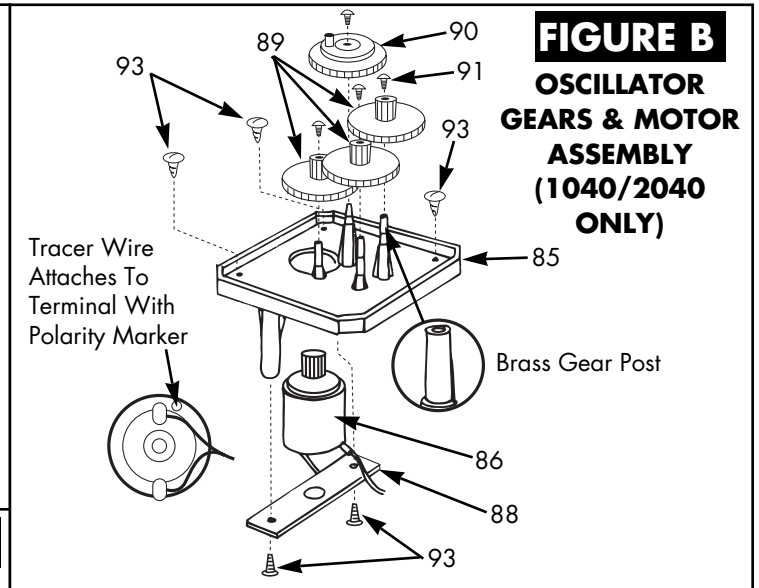

**FIGURE B**  
OSCILLATOR  
GEARS & MOTOR  
ASSEMBLY  
(1040/2040  
ONLY)

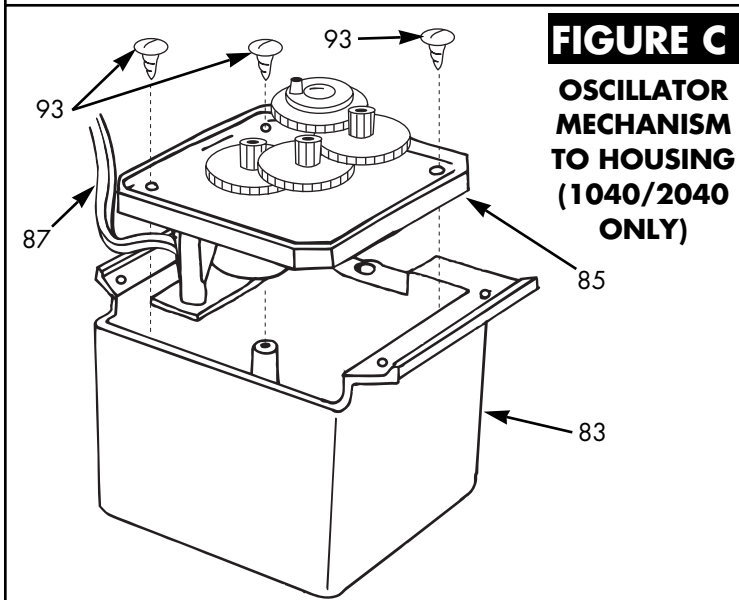

**FIGURE C**  
OSCILLATOR  
MECHANISM  
TO HOUSING  
(1040/2040  
ONLY)

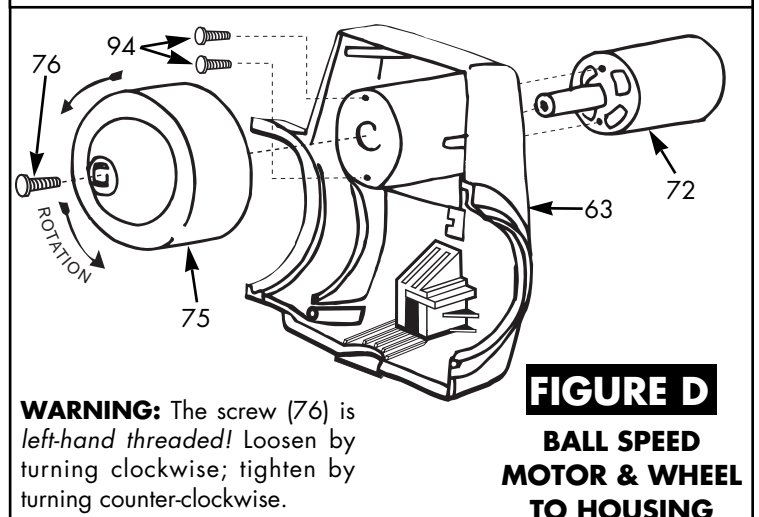

**FIGURE D**  
BALL SPEED  
MOTOR & WHEEL  
TO HOUSING

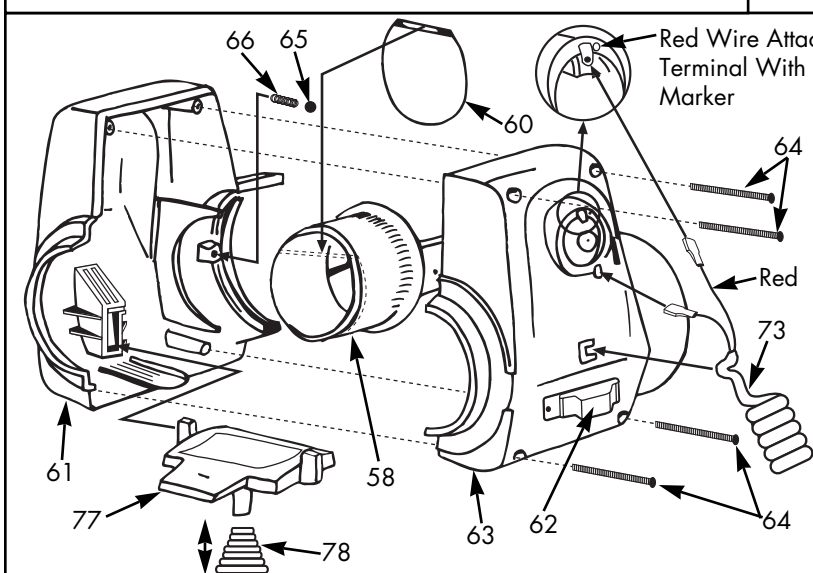
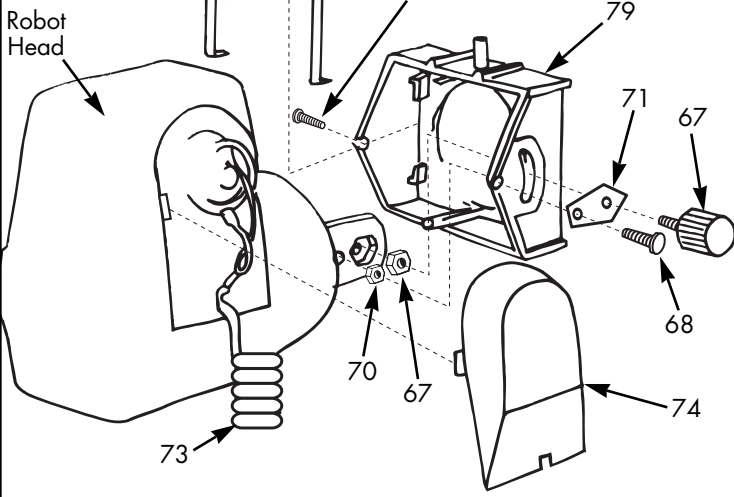

**FIGURE E**  
ROBOT HEAD ASSEMBLY

1. When disassembling the robot head, do not let the Steel Ball and Spring (65, 66) fall out of the Left Housing (61), since they're small and easy to lose! A bit of grease will hold them in place when reassembling. Work atop a towel to prevent loss of parts.
2. When assembling left and right Robot Head Housings (61 & 63), the Friction Block (77) and Spring (78) must be compressed slightly in order for the two halves to fit together.
3. A small amount of superglue (cyanoacrylate) holds the Ball Discharge Spring (60) onto the Discharge Tube (58). Scrape off old glue before replacing the spring.

**FIGURE F**

**ROBOT HEAD TO PIVOT GUIDE**



**FIGURE G**

**OSCILLATOR COVER TO UPPER GUIDE**

When attaching the Oscillator Motor Cover (83) to the robot, move the Oscillator Control Levers (81 & 82) to positions 1 and 6 (see page 9). This makes it easier for the oscillator drive shaft to fit between the levers.

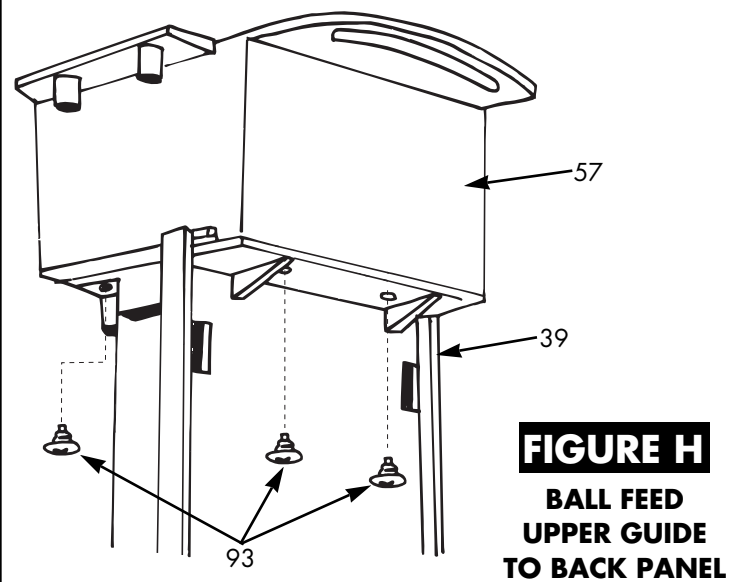
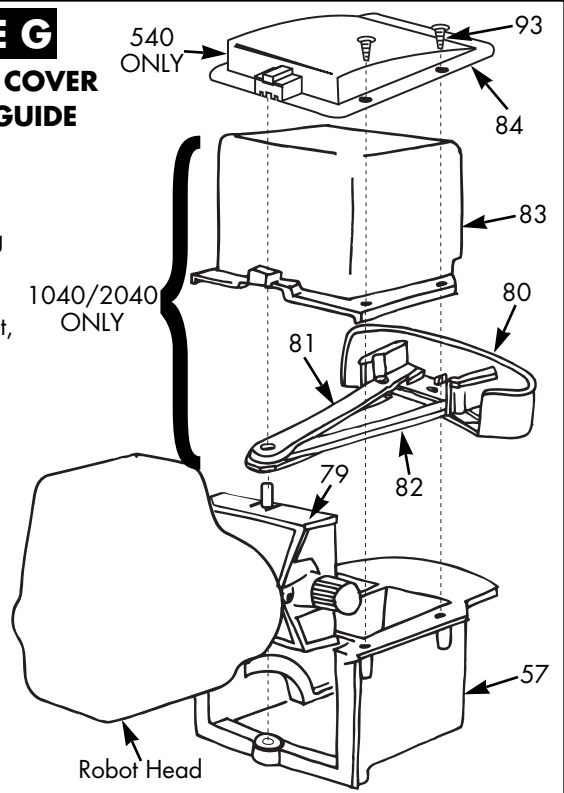

**FIGURE H**  
**BALL FEED UPPER GUIDE TO BACK PANEL**

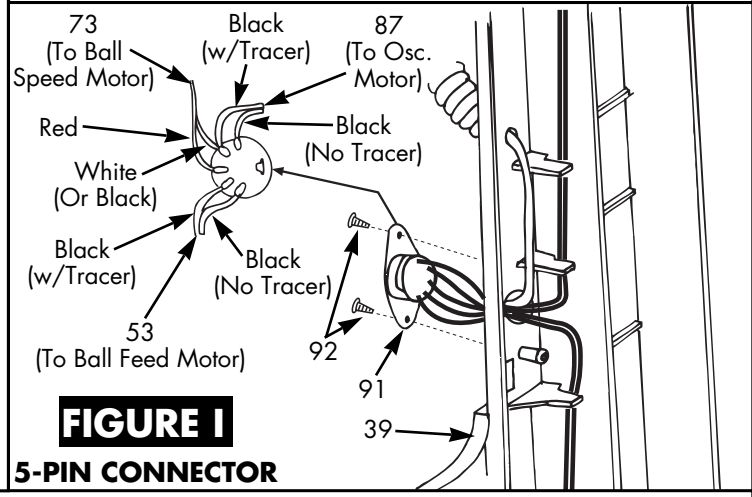

**FIGURE I**  
**5-PIN CONNECTOR**

**FIGURE J**

**BALL FEED MOTOR & GEARS ASSEMBLY**

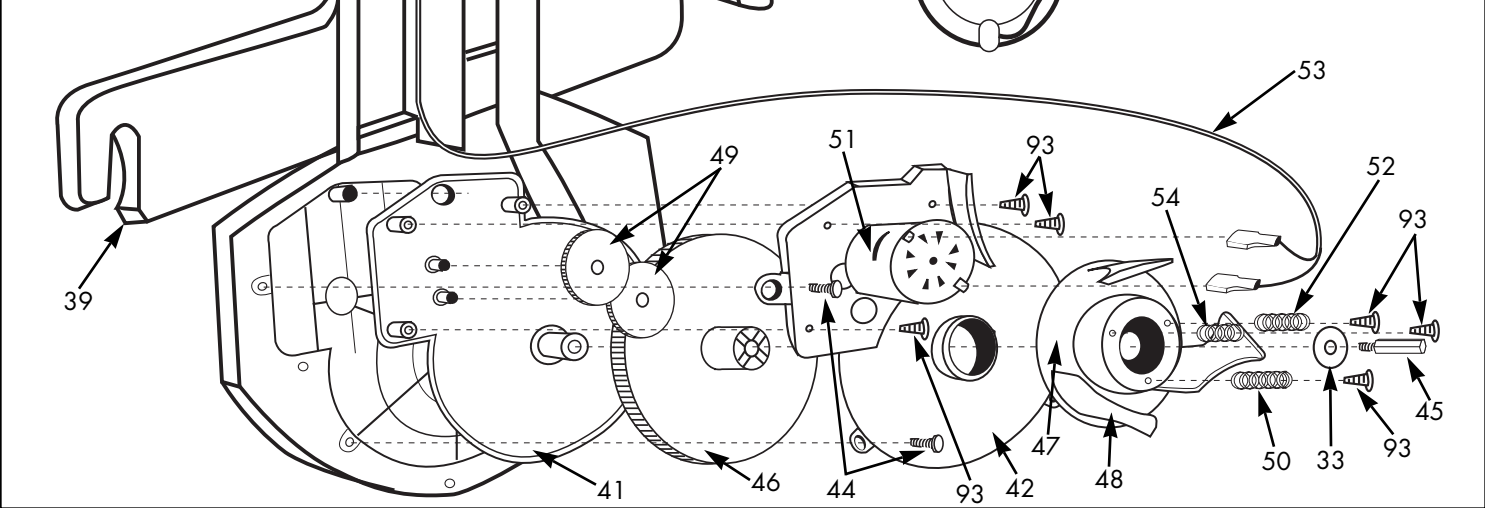

# PARTS LIST FOR NET ASSEMBLY (2040 ONLY)

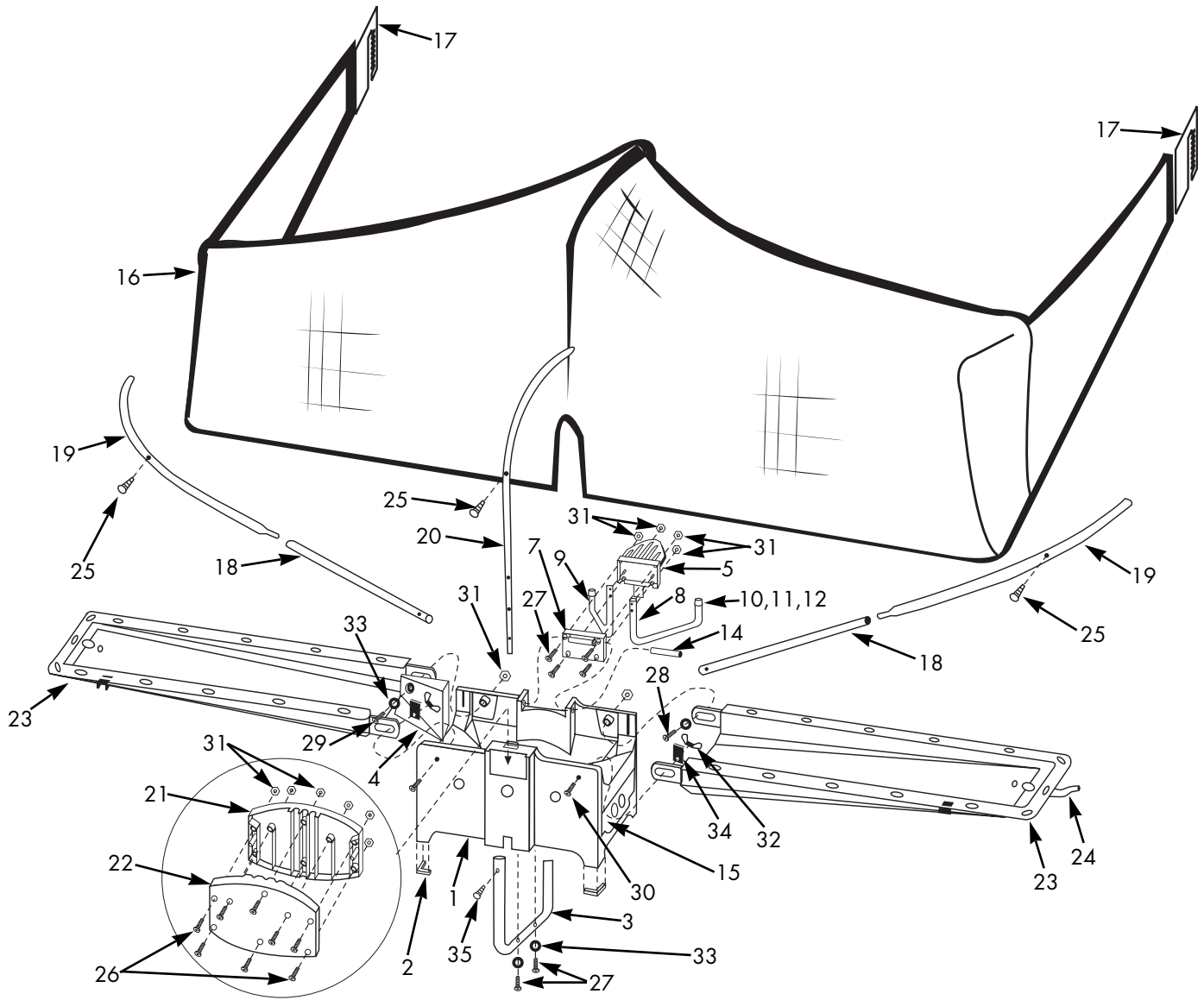

**NOTE:** The key numbers on this parts list correspond to the numbers used to identify parts in this manual.

| Key# | Part #    | Item                                   | Qty. |
|------|-----------|--|------|
| 1    | 2000-100  | <b>Center Trough</b>                   | 1    |
| 2    | 2000-101  | CT Rubber Feet                         | 4    |
| 3    | 2000-102  | CT U-Shaped Support Tube               | 1    |
| 4    | 2000-103  | CT Wedge Filler                        | 1    |
| 5    | 2000-104  | CT Support Plate, Front                | 1    |
| 6    | 2000-106A | CT Front Support Plate Pad (not shown) | 1    |
| 7    | 2000-108  | CT Support Plate, Back                 | 1    |
| 8    | 2000-110  | CT Support Leg, L                      | 1    |
| 9    | 2000-112  | CT Support Leg, R                      | 1    |
| 10   | 2000-114  | CT Support Leg Rubber Tip, 1/2"        | 2    |
| 11   | 2000-116  | CT Support Leg Rubber Tip, 3/4" (std.) | 2    |
| 12   | 2000-118  | CT Support Leg Rubber Tip, 1"          | 2    |
| 13   | 2000-120  | CT Rubber Spacer-Washer (not shown)    | 4    |
| 14   | 2000-122  | CT Pivot Pin                           | 1    |
| 15   | 2040-124A | CT Ball Dam, 40mm                      | 2    |
| 16   | 2040-126  | <b>Net, 40mm</b>                       | 1    |
| 17   | 2000-127  | Side Net Extender, L & R Pair          | 1    |
| 18   | 2000-128  | Net Support Tube, Straight             | 2    |

| Key# | Part #   | Item                             | Qty. |
|------|----------|----------------------------------|------|
| 19   | 2000-130 | Net Support Tube, Curved, L & R  | 2    |
| 20   | 2000-132 | Net Support Tube, Curved, Center | 1    |
| 21   | 2000-134 | Net Support Plate, Front         | 1    |
| 22   | 2000-136 | Net Support Plate, Back          | 1    |
| 23   | 2000-138 | Ball Return Tray                 | 2    |
| 24   | 2000-140 | Tray Strap                       | 1    |
| 25   | 2000-300 | Net Retaining Screw              | 3    |
| 26   | 2000-302 | #8 x 1" Machine Screw            | 8    |
| 27   | 2000-304 | #8 x 3/4" Machine Screw          | 6    |
| 28   | 2000-306 | #8 x 1/2" Machine Screw          | 2    |
| 29   | 2000-307 | #8 x 5/8" Machine Screw          | 1    |
| 30   | 2000-308 | #8 x 1" Hex Bolt                 | 2    |
| 31   | 2000-310 | #8 Hex Nut                       | 16   |
| 32   | 2000-312 | Wing Nut                         | 2    |
| 33   | 2000-314 | Large Washer                     | 7    |
| 34   | 2000-315 | Clip Washer                      | 2    |
| 35   | 2000-316 | #8 x 3/8" Machine Screw          | 1    |

# PARTS LIST FOR ROBOT BODY ASSEMBLY/BALL BUCKET

| Key# | Part #     | Item  | Qty. |
|------|------------|---|------|
| 36   | 1040-100   | Ball Bucket <sup>1,5</sup>  | 1    |
| 37   | 1040-101   | Ball Bucket Pad <sup>1,5</sup>  | 1    |
| 38   | 1040-105   | Bucket Extender <sup>1</sup>  | 1    |
| 39   | 2040-142   | <b>Ball Feed</b> Back Panel, 40mm   | 1    |
| 40   | 2000-144   | BF Collector Plate <sup>2</sup>   | 1    |
| 41   | 2000-145   | BF Mounting Plate   | 1    |
| 42   | 2040-147   | BF Top Cap, 40mm  | 1    |
| 43   | 2040-147-1 | BF Top Cap Plug (not shown)   | 1    |
| 44   | 2000-318   | BF #4 x <sup>5</sup> / <sub>16</sub> " Machine Screw  | 4    |
| 45   | 2040-319   | BF Extended Hex Screw   | 1    |
| 46   | 2000-149   | BF Main Gear  | 1    |
| 47   | 2040-151A  | BF Pickup Wheel, 40mm   | 1    |
| 48   | 2040-153   | BF Pickup Finger, 40mm  | 3    |
| 49   | 2000-155   | BF Transfer Gear  | 2    |
| 50   | 2040-157   | BF Spring, Long   | 1    |
| 51   | 2000-158   | BF Motor w/Gear   | 1    |
| 52   | 2040-159   | BF Spring, Medium   | 1    |
| 53   | 2000-160   | BF Power Wire (Figs. J & I, pg. 25)   | 1    |
| 54   | 2040-161   | BF Spring, Short  | 1    |
| 55   | 2040-162   | BF Clear Front Cover, 40mm  | 1    |
| 56   | 2040-163   | BF Jamstopper, 40mm   | 1    |
| 57   | 2040-164A  | BF Upper Guide, 40mm  | 1    |
| 58   | 2040-166A  | BF Discharge Tube, 40mm   | 1    |
| 59   | 2000-168   | BF Discharge Tube Brake   | 2    |
| 60   | 2000-170A  | BF Discharge Spring (Fig. E, pg. 24)  | 1    |
| 61   | 2040-172   | <b>Robot Head</b> Housing, L, 40mm  | 1    |
| 62   | 2040-173   | Ball Size Switch  | 2    |
| 63   | 2040-174   | RH Housing, R, 40mm   | 1    |
| 64   | 2000-320   | RH #8 x 1 <sup>3</sup> / <sub>16</sub> " Machine Screw  | 4    |
| 65   | 2000-176   | RH Steel Ball   | 1    |
| 66   | 2040-178   | RH Steel Ball Spring  | 1    |
| 67   | 2040-180   | RH Angle Adjustment Knob, 40mm  | 1    |
| 68   | 2040-321   | RH Pivot Screw  | 2    |
| 69   | 2000-322   | RH Angle Adjustment Knob Nut  | 1    |
| 70   | 2040-323   | RH Pivot Screw Nut  | 2    |
| 71   | 2000-182   | RH Angle Pointer  | 1    |
| 72   | 2000-184   | <b>Ball Speed</b> Motor w/Brass Shaft   | 1    |
| 73   | 2000-186   | BS Coiled Power Wire  | 1    |
| 74   | 2000-188   | BS Motor Cover  | 1    |
| 75   | 2000-190   | BS Discharge Wheel  | 1    |
| 76   | 2000-324   | BS Discharge Wheel Screw (LH Thread)  | 1    |
| 77   | 2040-192A  | BS Friction Block, 40mm   | 1    |
| 78   | 2000-194   | BS Friction Block Spring  | 1    |
| 79   | 2040-196   | <b>Oscillator</b> Pivot Guide, 40mm   | 1    |
| 80   | 2000-198   | Osc. Control Lever Adapter <sup>1,2</sup>   | 1    |
| 81   | 2000-200A  | Osc. Control Lever, L <sup>1,2</sup>  | 1    |
| 82   | 2000-202A  | Osc. Control Lever, R <sup>1,2</sup>  | 1    |
| 83   | 2000-204   | Osc. Motor Cover <sup>1,2</sup>   | 1    |
| 84   | 540-204    | Oscillator Cap <sup>5</sup>   | 1    |
| 85   | 2000-206   | Osc. Motor Mounting Plate <sup>1,2</sup> (Fig. B)   | 1    |
| 86   | 2000-208   | Osc. Motor w/Gear <sup>1,2</sup>  | 1    |
| 87   | 2000-210A  | Osc. Power Wire w/Connector <sup>1,2</sup> (Fig. B)   | 1    |
| 88   | 2000-212   | Osc. Motor Mounting Bracket <sup>1,2</sup>  | 1    |
| 89   | 2000-214   | Osc. Transfer Gear <sup>1,2</sup> (Fig. B, pg. 24)  | 3    |
| 90   | 2000-216   | Osc. Drive Gear <sup>1,2</sup> (Fig. B, pg. 24)   | 1    |
| 91   | 2000-326   | Osc. #1 x <sup>3</sup> / <sub>16</sub> " Machine Screw <sup>1,2</sup>   | 4    |
| 92   | 2000-218   | 5-Pin Connector   | 1    |
| 93   | 2000-328   | #4 x <sup>3</sup> / <sub>8</sub> " Self Tapping Screw 21 <sup>1</sup> / <sub>24</sub> <sup>2</sup> /16 <sup>5</sup> | 1    |

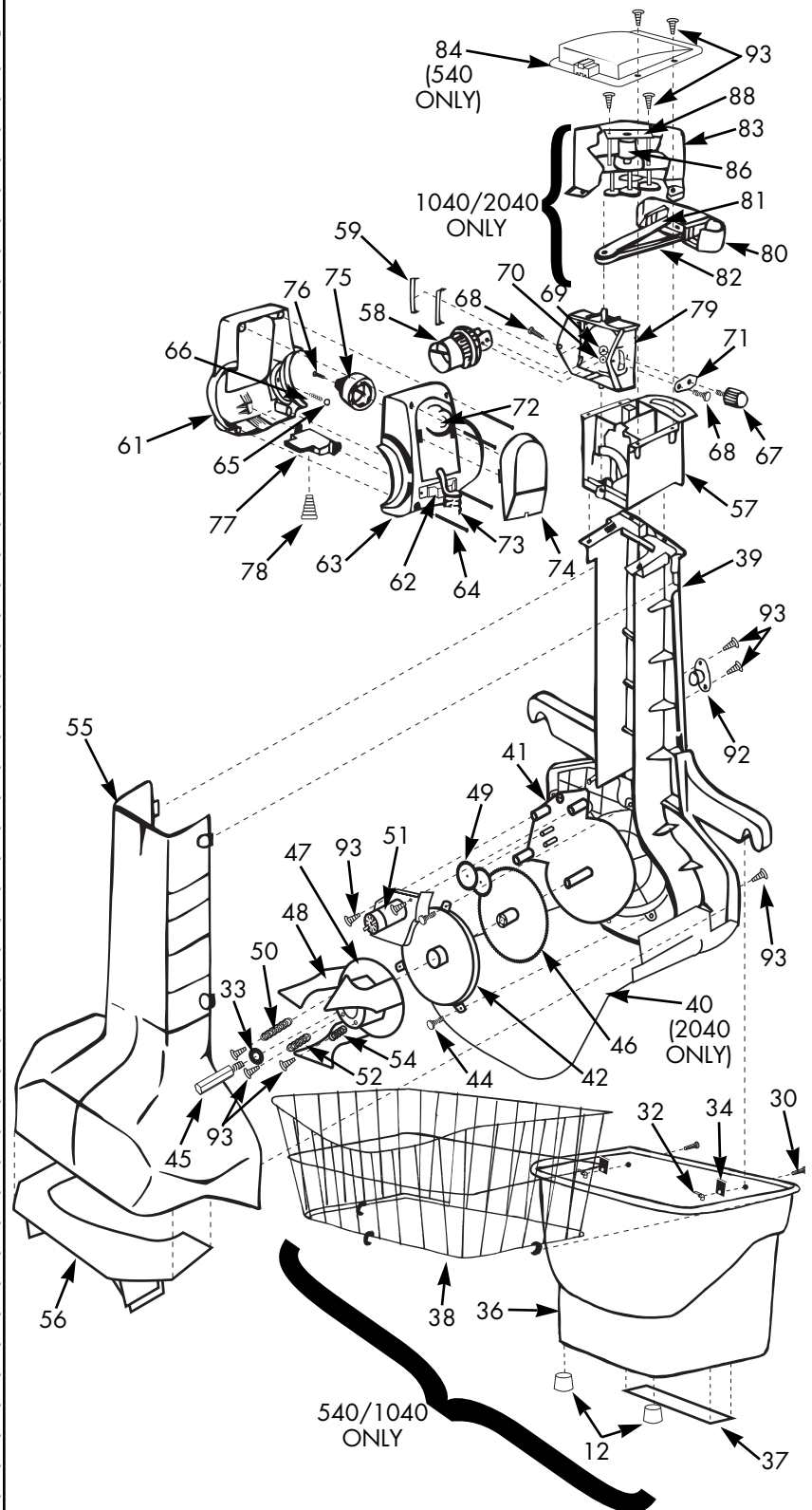

| Key# | Part #     | Item  | Qty. |
|------|------------|---|------|
| 94   | 2000-330   | #2 x <sup>1</sup> / <sub>4</sub> " Machine Screw (Fig. D) | 4    |
| 95   | 2000-220   | Connector Cable (not shown)                               | 1    |
| 96   | see pg. 20 | Transformer (not shown)                                   | 1    |
| 97   | 2000-224   | Control Box (not shown) <sup>1,2</sup>                    | 1    |
| 98   | 540-224    | Control Box (not shown) <sup>5</sup>                      | 1    |
| 99   | 2000-225   | Control Box Rubber Tip (not shown) <sup>1,2</sup>         | 1    |
| 100  | 540-219    | Cable Clip (not shown) <sup>5</sup>                       | 1    |

<sup>1</sup>Robo-Pong 1040; <sup>2</sup>Robo-Pong 2040; <sup>5</sup>Robo-Pong 540

# OWNER'S MANUAL

## SERVICE AND REPAIR

## HOW TO ORDER REPLACEMENT PARTS

## SERVICE POLICY

## WARRANTY

# NEWGY ROBO-PONG®

## TABLE TENNIS ROBOT

Thank you for purchasing a Newgy Robo-Pong robot. We inspect our products to be sure they are of high quality and free of defects. However, if you need service or advice on your robot, please contact our Customer Service Department (contact info at the lower left corner of this page).

Please call us for return authorization before you send in your robot for repair. Often, repairs can easily be handled on the phone. Have you tried to troubleshoot the problem by trying the tips on pages 21–23? You may also want to visit our website to see if any information has been updated. When you do call, please have your serial number and this manual handy. (The serial number is located on the Support Flange—see Figure 17, page 13.) If, after talking with our Service Department, you need to send in your robot, be sure to include a brief note describing the problem and listing your daytime phone number and shipping address.

You may order from our Customer Service Department a current parts price list, or you may look it up on our website (<http://www.newgy.com/Products/PricePartsRobo2040.html>). If you know which part you want to order (see pages 26 & 27), you may order it by phone if you have a credit card (Visa, MasterCard, American Express, or Discover). Otherwise, you will need to fill in a parts order form and include a check or money order along with your order.

**OUT OF WARRANTY SERVICE POLICY:** When your 1-Year Limited Warranty expires, the manufacturer will repair any normal wear and tear to the robot for a \$30 service charge plus \$6 shipping and handling for a period of 5 years from date of purchase. This policy does not cover damage due to abuse, misuse, or improper handling and applies only to Newgy robots bought from the USA.

Your Warranty Card (included with this manual) should be mailed within 15 days of purchase. A copy of the warranty information is given below. Be sure to keep your purchase receipt. We suggest you keep your receipt with this manual and record the following information:

Date Purchased \_\_\_\_\_ Serial # \_\_\_\_\_

Store Name \_\_\_\_\_ City, State \_\_\_\_\_

### LIMITED 1 YEAR WARRANTY

Manufacturer warrants to the original retail purchaser this product to be free from defects in material and workmanship for a period of 1 year from date of purchase.

Should this product become defective due to material or workmanship during the warranty period, contact our Customer Service Department describing the defect. Always provide your serial number. We will provide you with return authorization and shipping instructions. If you are asked to return the product, pack it securely and ship it **PREPAID**.

If defective as provided by the terms of this warranty, we will, at our option, repair or replace the product and return it to you prepaid.

This warranty is not transferable and does not cover normal wear and tear, or damage caused by improper handling, installation, or use. This warranty is void if the product is in any way abused, damaged, or modified from its original state.

This warranty gives you specific legal rights, and you may have other rights that may vary from state to state.



NEWGY INDUSTRIES, INC.  
805 TEAL DRIVE  
GALLATIN, TN 37066 USA  
PHONE 615-452-6470  
FAX 615-230-9785  
E-MAIL [newgy@newgy.com](mailto:newgy@newgy.com)  
WEB [www.newgy.com](http://www.newgy.com)